

See Our Advertisement
on Page No.1



Sadhi Machinery Plastic Product
ISO 9001 : 2008 Certified Company
Mobile : 098983 96971, 098239 92384
E-mail : info@sadhimachinery.com
Website : www.sadhimachinery.com

INDIA

PLASTIC



A MARKET LEADER in PLASTIC INDUSTRIES Latest...

USE plastic go green

COMPLAST
International Exhibition
SERVA
JULY 13-15, 2018
KCC, MANDRI, NEWRA

Bi-monthly
Plastic News Magazine

The Plastic Revolution only

Visit us : www.plasticchallenge.in

Forthcoming Exhibitions Page No. : 30 | Editorial Page No. : 31 | July 2018 | Vol. No. : 20 | No. : 04 | Pages : 78 | Rs. : 200 | \$: 10

We Support:



mfrs

World Class
screw & barrel
for PLASTIC PROCESSING
MACHINERY

Devikrupa group
Help You Invent the Future
(AN ISO 9001 : 2008 Certified Company)

CELEBRATING
17
Years

Ready Stock
"Up To 550 Kg Output
Twin Extruder's spares
Avail



Products

- > Twin Parallel Screw
- > Twin Hole Barrel
- > Twin Barrels (Sleeve Fitted, Parallel)
- > Barrier Screw
- > Single Screw
- > Single Barrel
- > All Grooved Feed Bush
- > All types of Plastic Machinery Spare Parts
- > Bimetallic Screw & Barrel
- > Food Processing screw & Barrel



DEVIKRUPA INDUSTRIES

(AN ISO 9001 : 2008 CERTIFIED COMPANY)



Plot No.67/14, Road L-9, Nr.Abhyudaya Co-Op.Bank, Opp.Subham Extrusion Technic,
Phase-1, G.I.D.C., Vatva, AHMEDABAD - 382 445. (Gujarat) INDIA
Mobile : +91-94287 34532, 98259 23220,
Phone : 079 - 40083831 (3 lines) Fax : 079 - 40083832
E-mail : info@devikrupaindustries.com , info@twinscrewbarrel.com
Web : www.devikrupaindustries.com , www.twinscrewbarrel.com



Website



S2T-V SERIES
VERTICAL CLAMPING VERTICAL
SCREW TYPE INJECTION



SV SERIES
VERTICAL CLAMPING VERTICAL
SCREW TYPE INJECTION



SV-R-2C SERIES
TWO COLOR ROTARY TYPE VERTICAL
INJECTION MOULDING MACHINE



SVT SERIES
VERTICAL SCREW TYPE INJECTION
& HORIZONTAL TOGGLE CLAMPING

Swift Auxil Technik Pvt. Ltd.

Mfg. : Vertical Injection Molding Machine & Plastic Auxiliaries

Plot No. 320, Road No.-5, Kathwada G.I.D.C., Ahmedabad-382430. (Gujarat) India
Tele/Fax : (079) 22900718, E-mail: swiftechpvtltd@gmail.com, Mobile : +91 9724797978
Web site : www.swiftauxil.com

Vertical Injection Molding Machine & Plastic Auxiliaries



SV-SS SERIES
SINGLE STATION SLIDE TYPE VERTICAL
INJECTION MOULDING MACHINE



SV-DS SERIES
DOUBLE STATION RIGHT ANGLE
VERTICAL SCREW TYPE INJECTION
MOULDING MACHINE



SV-R SERIES
ROTARY TYPE VERTICAL SCREW TYPE
INJECTION MOULDING MACHINE



Serving the entire gamut of plastics applications

- Automotive
- Packaging
- Electrical, Electronics
- Consumer Goods & Industrial
- House Ware
- Medical
- & Telecommunication
- Components Construction
- Furniture
- White Goods
- And many more...

Major product lines offered by us:

- Monolayer Blown Film Lines
- ABA (2 Extruder 3 layer) Blown Film Lines
- Three-Layer (ABC) Blown Film Lines
- PPTQ Blown Film lines
- Compounding machine
- Auxiliary accessories of all above lines



**ABA Co-Extrusion High Speed
Blown Film Machine**



AFFLUENT

extrusion technik pvt ltd
EXPERTISE IN EXTRUSION



Monolayer
Rotating die



Monolayer High Speed
Blown Film Machine

Monolayer Mini
Blown Film Machine



AFFLUENT
extrusion technik pvt ltd

CORPORATE OFFICE :

Affluent Extrusion Technik Pvt Ltd

Plot No : 14, Krishna Industrial Park – 1, Nr. Mahakali Temple,

Odhav-Kathalal Highway, Kubadthal, AHMEDABAD – 382430. Gujarat – INDIA

Phone : 9662062257, 9824268779

Email : affluentextrusion@gmail.com Web : www.aetextrusion.com



Gravure & Flexo Rubber Roll



Bow Roll



Polyurethane Roller



Aluminum Roll



Embossing Roller

Air Shaft



Cooling Roller



Scroll Rolls



Hard Chrome Plated Rollers

Product Range For Plywood Industries

Applicator Rolls, Anvil Rolls, Band Saw Wheels, Feed Rolls, Glue Spreader Rolls, Grooved Rolls, Serrated Rolls, Laminated Rolls, Pull Rolls, Wide Bed Sander Rolls, Doctor Rolls, Cooling Rolls, N N Stick Courting Rolls, High Release Coating Rolls, Contact Rolls



ADVANCE RUBBER INDUSTRIES

Textile | Paper | Plastic | Printing | Steel Industries

Mfgs Of : All Types Of Industrial Rubber Roller

Factory.: No. 41, Chirag Industrial Estate, Nr.

Revabhai Estate, C.T.M., Amraiwadi,

AHMEDABAD- 380026. (Gujarat) INDIA

Mobile :. +91- 9825340400

Phone.: +91-79- 25850682, 25852879

E-mail.: advancerubber@gmail.com

Website.: www.advancerubberindia.com,

www.rubberroller.co.in



500 ML DOUBLE HEAD WITH BOBBING.



200 ML TRIPLE HEAD WITH BOBBING.



Mfg. & Sales : Fully Automatic Plastic Blow Moulding Machines Containers in P.V.C., H.D.P.E., L.D.P.E, PETG & P.P. Materials from 5 ml to 10Ltrs



Sadhi Machinery Plastic Product™

AN ISO 9001 : 2008 Certified Company

Address : 149, Mahadev Estate - 1, Ramol Road, C.T.M., AHMEDABAD, Gujarat, (INDIA)

Mobile: 098983 90671, 098253 92384

E-mail: pairespolymers89@gmail.com, info@sadhimachinery.com

Website : www.sadhimachinery.com, www.sadhienterprise.com



Scan this QR Code
your App or Smartphone

Carry Bag Punching Machine & Die Punch

Only one stroke in 1000 bag punching



MACHINE'S SPECIFICATION

- Push Button & Foot Control Switch
- Side Adjustment
- Punching Machine with 3 Phase Motor, PP Sheet and L. R. Switch
- Speedy Working

First time in
INDIA

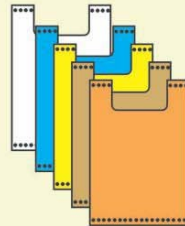

DIE-PUNCH

- Harden Tools Blade
- 1.6 mm Blade Thickness
- 50 mm Blade width
- 10 mm Plate
- 25 mm Dia Round Shaft

Manufactured by

VRUNDATM
enterprise

7/11, G.I.D.C. Makarpura, Nr. Susen Cross Road,
VADODARA - 390 010, Gujarat (INDIA)
Ph. : 91265 - 6537891 Mob. : 09824279291, 09227579291
Email : vrundaenterprise@yahoo.co.in

Website.: www.vrundaenterprise.com

SUPERIOR

THE LATEST ADDITION TO OUR LINE OF GMS RECYCLING PLANTS.



SPECIALISED PLANTS FOR EPS / XPS ALSO DEVELOPED WITH OUTPUT RANGE 50/100/200/300/500 KGS PER HOUR.

BENEFITS OF GMS MACHINES

- Very low repairs and maintenance or negligible after sales service required.
- We produce only high quality Italian Technology machines.
- High quality screw and barrels with 0% complains from clients till date.
- Compact design with minimum floor area.
- Fully Automatic Plants with minimum labour requirements.
- PP / PE / ABS / PC / HIPS or similar polymers do not need to be pre-heated/drying to run on our machines.
- Very low in power consumption 0.25 ~ 0.37 kw/kg, vis-à-vis any other Asian Machine.
- We can change the Screen / Filters online.
- We need only one operator for the machine.
- Round Dieface Pellets from our machine.

GMS PLASTIC MACHINERY PVT. LTD.
2-A2, COURT CHAMBERS, 35, NEW MARINE LINES, MUMBAI - 400020
E: satellite.gms@gmail.com | W: www.recycleplastics.in
T: (+91) 22 2200 7883 / (+91) 22 2200 6556



MARSO
A Trusted People

MARSO Machinery
Mfg. of Plastic Processing Machinery

Manufacturing of
High Speed Heater Cooler Mixer
with
Fully Automatic
Material Handling System.



High Speed Heater Cooler Mixer

Our Product Range

- High Speed Heater Cooler Mixer
- Automatic Raw Material Conveying System
- Automatic Weighing System
- Liquid Metering System
- Material Storage Silos
- Aspiration System
- Lab Mixer
- Hopper Loader Vacuum Conveying System



Plot No. 90/17, Bon Foam India Compound B/h. Bank Of India,
G.I.D.C., Vatva, **Ahmedabad** - 382445 Gujarat (**INDIA**)
info@marsomixer.com, infomarsomixer@gmail.com
+91 96876 17221 **Phone No.** +91-79-48911221

Visit Us.: www.marsomixer.com



KESAR EXTRUSIONS

EMPOWERING THROUGH IMAGINATION



KESAR EXTRUSIONS

C-21, Devashray Industrial Park, Nr. New Maninagar, Opp. N.K.H. Engineering, Phase 4, G.I.D.C.,
Vatva, Ahmedabad - 382 445, India.

+91 86908 29929
info@kesarextrusions.com
www.kesarextrusions.com

Visit Us.



International Plastics Exposition
Hall No. : 4
Stall No. : M-4



Product Range :

MANUFACTURER OF PLASTIC EXTRUSION MACHINERY

- Monolayer Blown Film Plant
- ABA Blown Film Plant
- Multilayer Blown Film Plant
- PPTQ Blown Film Plant
- Re-Process Plant
- Sutli (Synthetic String) Plant
- Lab Model



Monolayer Blown Film



ABA Blown Film Plant
(Two Extruder Three Layer)



Multilayer Blown Film Plant



PPTQ Downward Blown Film



Reprocess Plant



Sutli (Synthetic String) Plant

Contact Details :

Address : Plot No. 388, Gopal Charan Industrial Hub,
Bakrol-Bujrang, Ahmedabad, Gujarat, INDIA.

Contact : +91 9510774560

Email : info@vmosaextrutech.com

Web. : www.vmosaextrutech.com





OM Enterprise

Manufacturers of :
**Carry Bag Punching
Machine & Die Punch**



Export Quality Products



**Special for
Non woven
Bag Cutting**

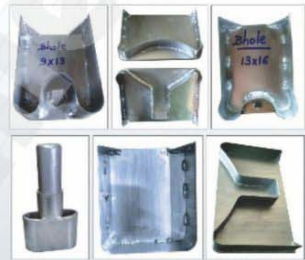

More Than **1000** Bag Punching

**in
One Stroke**



Overall Dimension	Technical Specification
<p>Height : 59 inch X 20 inch X 34 inch</p> <p>Base Plate : 500 mm X 500 mm X 25 mm</p> <p>Production Capacity : 1 stroke in 1000 Bag</p>	<p>Description : Semi Automatic Carry Bag Punching Machine</p> <p>Operating : Push Button & Foot Control Switch</p> <p>Power Required : 2 HP 3 Phase</p>



Maintenance

*Quality
without
Compromise*

OM Enterprise

247, G.I.D.C., Makarpura, VADODARA-390 010 (Guj.) INDIA.

Mr. HITESH MAKWANA +91 91738 16296
PINTU MAKWANA +91 99781 83564

Website : www.omenterprisevadodara.com

E-mail : omenterprisevadodara@gmail.com

Manufacturer & Exporter of :
P.V.C. Profile Plant / Pipe Plant,
H.D.P.E. Pipe Plant,
Garden Pipe Plant,
Twin Screw Down Stream,
Hi-Speed Mixer & Grinder



Twin Screw Pipe Extrusions Line



Die Head



Vacuum Sizing Tank



Tube / Pipe Auto Cutter



Tube / Pipe Traction Unit

Manufacturer of :

Pipe Plant Range :

- Twin screw pipe Plant
- Vacuum/Cooling sizing Tank
- Spray Tank
- Tube / Pipe Traction unit
- Rotary Auto cutter
- Tilting
- PPR / HDPE / LD Pipe extrusions

- Grooved feed system
- Garden pipe extrusions

Profile Plant Range :

- Twin Screw PVC Profile Extrusion
- Calibration Table
- Hydraulic Haul Off
- Profile Auto Cutter
- High Speed Heater-Cooler Mixer

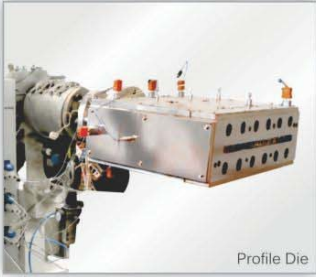

Profile Die



Calibration Table



Hydraulic Haul Off



Twin Screw Profile Extrusions Line



Profile Auto Cutter

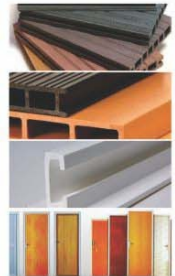



BLOW ENTERPRISESTM

SINCE 1986

Manufacturer & Exporter of Fully Automatic Plastic Extrusion Blow Molding Machine

Suitable To Make Containers In Blow HDPE, LDPE, PVC, PET-G & PP Materials.
Product Range 5ml-100 Litres



MULTICAVITY AUTO DEFLASHING BLOW MOULDING MACHINE



MULTILAYER PARISON CONTROLLED BLOW MOULDING MACHINE



SINGLE STATION DOUBLE STATION	VIEW STRIPE CONTINUOUS PARISON	AUTO DEFLASHING IN MOLD LABELING	MULTI-CAVITY MULTI-LAYER	PARISON CONTROLLER ACCUMULATOR HEAD
----------------------------------	--------------------------------------	---	-----------------------------	--

www.blowengg.com | www.blowent.com

www.blowengg.com
www.blowent.com

MACHINE SUCCESSFULLY RUNNING IN EXPORTS

- KUWAIT 🇰🇼
- SRI LANKA 🇱🇰
- NEPAL 🇳🇵
- BANGLADESH 🇧🇩
- UAE 🇦🇪
- AFRICAN CONTINENT 🇰🇪
(KENYA, NIGERIA, ETHIOPIA, BURUNDI, TANZANIA & MALAWI)



INDUSTRIES CATERING TO

	Food Processing
	Kids Zone
	Agriculture
	Pharmaceuticals
	FMCG
	Automobile
	Chemicals
	Lubricant

DOUBLE STATION HYDRAULIC BLOW MOULDING MACHINE

DOUBLE STATION 4 CAVITY AUTO DE-FLASHING BLOW MOULDING MACHINE

DOUBLE STATION HIGH SPEED BLOW MOULDING MACHINE



BLOW ENGINEERING™
(Export Division)

+91 98191 25394 | +91 9769223575
Tel: (022) 28520554. Telefax: 28563419
+91 84220 65666 | +91 9821106428
Email: response@blowengg.com | blowengg@hotmail.com
1/2 Milan Sadan , Khairani Road,Saki Naka, Andheri (East), Mumbai - 72 ,INDIA.

Connect to us on :
#BLOWENGG



Grab India's Best Investment Opportunity
with **Satyaja Infratech at Dholera SIR**

India's First & Biggest Smart City Developing in 920 sq. Km.

**LOWEST
PRICE
GUARANTEE**

APPROVED AND UPCOMING PROJECTS

Ahmedabad- Dholera Express Highway

Ahmedabad- Dholera Metro Rail

Dholera International Airport

World's Largest Solar Power Plant of 5000 MW

~~2880~~
2448 Per Yard

Meet our executive and do Site visit
Before **31st July** for Avail offer

Current Running Projects at Dholera SIR

Total built-up area	Contractor	Construction Cost
16500 <small>sqm</small>	CCEL	73 Cr.
Total STP Capacity	Contractor	Construction Cost
10 <small>MHD</small>	L&T	53.9 Cr.
Total OETP Capacity	Contractor	Estimated Cost
20 <small>MHD</small>	TBD	145 Cr.
Total WTP Capacity	Contractor	Construction Cost
50 <small>MHD</small>	SPML	90 Cr.
Total Road Length	Contractor	Construction Cost
72 <small>km</small>	L&T	1734 Cr.

Location Advantage

Dholera SIR TP 1	3.5km
Metro & Express way Connectivity	5km
Dholera International Airport	8km
Ahmedabad (By New Express Way)	75km
Ahmedabad (By State Highway)	90km
Mumbai	500km

BLISS
— HOMES —

SATYAJA
INFRA TECH

PROJECT BY
SATYAJA INFRA TECH
308, Shivalik Highstreet, Judges Bungalows Road,
Nr. Mansi Tower, Satellite, Ahmedabad - 380 015.
Visit us on www.satyajainfratech.com

Call us : +91 72858 51888 | +91 98980 09493 Email: info@satyajainfratech.com

RAZOR SHARP . SUPER FAST .
Electric Chainsaw for Faster Cutting of Rejected Plastic



TWO MAN CHAIN SAW & ONE MAN CHAIN SAW are fully portable and extremely useful for 100 times faster cutting of damaged & rejected HDPE Pipes & Plastic Tanks.

sharpex

www.sharpexindia.com

Our Esteemed Customers : Sintex | Kisan | Aishwariya Plastics | Dutron Plastics
Jain Irrigation | National. Plastics | Sangir Plastics | Shri Venkatesh Filaments Pvt. Ltd.
The Supreme Industries Ltd. | Time Technoplast Ltd | VHCL Industries Ltd.

Sharpex Engineering: Plot No. 1-5, L - Type Estate, GIDC, Odhav, Ahmedabad 382415.

M: 98 98 78 87 87 | **E:** info@sharpex.com | **SMS:** SHARPEX <SPACE> HDPE to 52424 | **TOLL FREE:** 1800-313-3303



**BHAVANI
ENGINEERING**

Mfrs. of :
All Kind Of Cylindrical
Conical, Single and
Twin Screw Barrel



Injection Moulding Screw & Barrel



Single Screw Barrel



Conical Twin Screw & Barrel



Single Screw Extrusion Screw



Parallel Twin Screw Barrel

Product Range	
Screw :	Barrel
• Single Screw	• Groove Feed Barrel
• Twin Parred Screw	• Twin Front Barrel
• Twin Conical Screw	• Conical Barrel
	• Segmented Barrel



Groove Feed Sleeve Screw Barrel



BHAVANI ENGINEERING

Address : 50 Shree Nath Estate, Nr PNB Bank, Phase 1 GIDC Vatva,

AHMEDABAD-382445 (Gujarat) INDIA

Cell : 094265 61804, 090679 43766, 094276 21342,

E-mail : bhavaniengineering.1@gmail.com



Scan this code
on your app &
android smart
phone

www.bhavaniengineering.co.in

Manufacturer of:

- Hydraulic Bale press • Scrap Bale press • Hydraulic Cylinder
- Hydraulic Power pack & All type of Hydraulic Systems.



Hydraulic Baling press for wovvensack



Green nette Bale press



Fibc Jumbo bags bale press.



waste plastic bale press



Plastic Scrap Bale Press



Waste Paper Bale Press



Scrap Bale Press



FABRIC BALE PRESS

Features

- Hydraulic Bale Press 10 To 200 Ton Capacity
- Heavy Structure & Good Quality
- Low Maintenance & Service.



Shed No : 110, Gajanan Industrial Estate,
Near Steel connect , SP Ring Road,
Near Hathijan Ring Road circle, Vatva, Hathijan ,
Ahmedabad-382440 Gujarat, INDIA
Contact us : +91 9924125082, +91 9978423437
E-mail : utsav@aimindustries.co.in,
chirag@aimindustries.co.in

Visit us : www.aimindustries.co.in



Website



Manufacturer of ALL TYPES OF PLASTIC MACHINERY



Screw Type Toggle



Hyd. Press



Verticle Plastic Plunger
PLC Moulding Machine 1



Breaklight Press



Verticle Plastic Plunger
PLC Moulding Machine



Bakelight Heavy



Verticle Plastic Plunger Semi
Auto Moulding Machine



BAJARANG POWER PRODUCT

An ISO 9001:2015 Certified Company

3, Mahadevadi, Umakant Pandit Udyog Nagar,
Opp. Care Drinking Water, Rajkot-4 (Guj.) India
Cell.: 09426249925, 09426953585, 07567499919, Ph.: 0281-2360364

E-mail: bajrangpowerproduct@gmail.com, Web.: www.bajrangpowerproduct.com, www.twowheelersviceramp.com,

A Complete Solution for Woven Bag

Manufacturer & Exporter of Woven Sack Bag Making Plant & Machineries



Manual Bag Closing System



Automatic Bag Closing with Bag Infeed Device



Fabric Gusseting Cutting Machine



Gusseting-Cutting-Stitching-Machine



2/3/4 Colour Flexographic Bag to Bag Printing Machine



Fabric Cutting Machine

Other Product Range :

- Jumbo Woven Bag Cutting Machine
- Jumbo Woven Bag Cutting Machine with Spout Bailing Press



Fully Automatic Woven Bag Conversion Line

BLACKSMITH WOVEN CONVERSION

Plot No : 59 / A /12, Mahalaxmi Industrial Estate, Inside Maruti Estate, Nr. Kiran Industries, Phase - 1, G.I.D.C, Vatva, Ahmedabad - 382445. Guj. India.

Mobile : +91 99044 89494 / 7698974141

E-mail : jaydeep@wovenconversion.com / sales@wovenconversion.com

Website : www.wovenconversion.com / www.wovenbagconversion.com



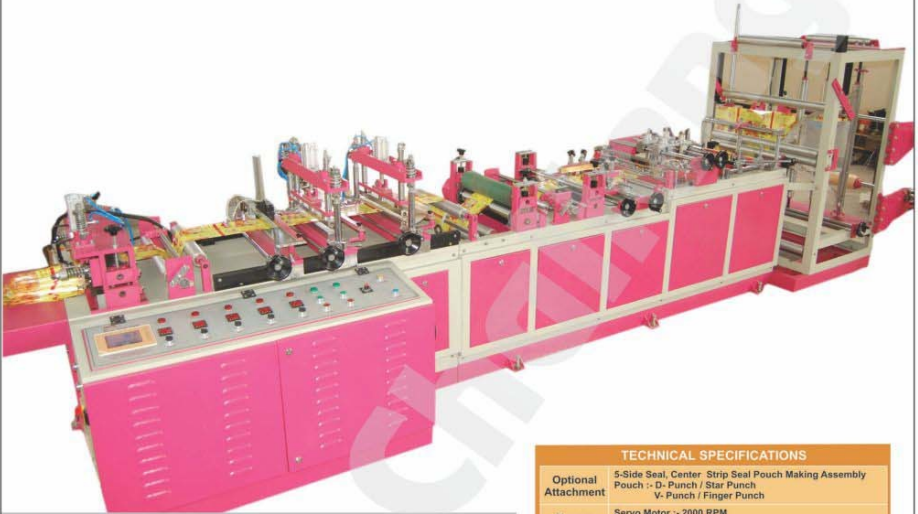

Product range -

- ▶ **PNEUMATIC OPERATED POUCH MAKING MACHINE**
- ▶ Center seal, center seal with gusset, center lip seal pouch making machine
- ▶ 3 side seal, folded side seal, Perforation pouch making machine.
- ▶ 2 and 3 side seal, Zipper and pouch making machine.
- ▶ Combined center seal, 3 side seal, perforation, five side seal pouch making machine.

- ▶ **MECHANICAL OPERATED POUCH MAKING MACHINE.**
- ▶ Center seal, center seal with gusset pouch making machine.
- ▶ 3 side seal, zipper, stand up pouch making machine.
- ▶ Automatic high speed combination of 2 and 3 side seal, Zipper,
- ▶ Stand up and reusable, center seal pouch making machine

TECHNICAL SPECIFICATIONS

Optional Attachment	5-Side Seal, Center Strip Seal Pouch Making Assembly Pouch -> D-Punch / Star Punch V-Punch / Finger Punch
Movers	Servo Motor -> 2000 RPM Variable -> 2HP With Gearbox
Elect. Power Consumption	MAX. 16KW - 3PH 415V (A.C.) 50HZ
Air Consumption	12 Cfm 7 Bar Pressure
Machine* Speed	Water Contain Less Than 0.01% Up to 182 P/Min.

*Machine Speed Depends Up Laminate, Thickness & Pouch Size

MODEL - PTP - 450P

	Center Seal (WXL in mm)	Side Seal	Four Side Seal + Glasset
Pouch Size	Min-75 X 75	50 X 50	90 + 50 X 75
	Max - 375 X 1000	400 X 1000	275 X 500 + 100
Max Roll Width	800 mm		



PRIMO TECH PACK

ADD: - 199, SHUBH INDUSTRIAL ESTATE, OPP-ZAVERI ESTATE, KATHWADA G.I.D.C, KATHWADA, AHMEDABAD - 382415 (Gujarat) INDIA
 WEB: - www.primotechpack.com
 Mail: - bhaves@primotechpack.com / info@primotechpack.com



एन. एस. आई. सी.
NSIC
ISO 9001 : 2008



Toggle Clamping Injection Moulding Machine **20 to 550 Ton**

Universally Proven Machines For
Accurate Moulding and
Power Saving

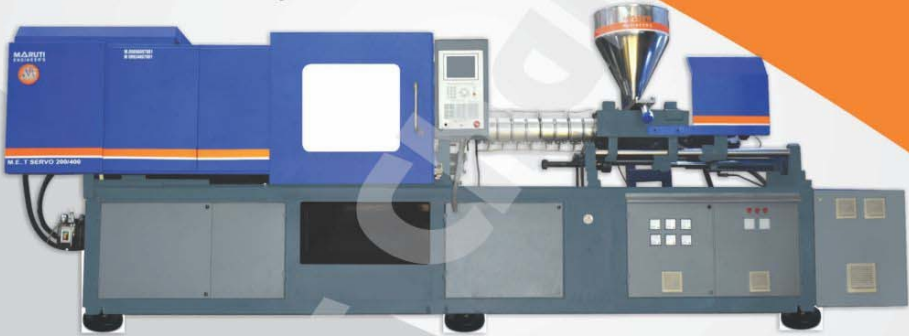

Injection Moulding Machine



Mfg. : Toggle Type Injection Moulding M/c. & Repairing



Regd. Office : 18, Krishna Industrial Park, Nr. Zaveri Estate,
Kathwada-Singarva Road, Kathwada, Ahmedabad-382430,
Gujarat, INDIA **Mobile :** +91-98980 97881, 77788 97581
E-mail : info.marutiengineers@gmail.com
Visit US : www.maruti-engineers.com



HARI KRUPA INDUSTRIES

Mfg & Suppliers :

All type of Plastic Injection Moulds, Pipe Fitting Mould
(PVC / CPVC) ASTM Fittings / Cap & Closer Mould
Housever & Blow Mould , Paint Container Moulds



Exporters of Plastic Moulds

Specialist in
PVC Fitting Mold



www.harikrupamould.com

HARI KRUPA INDUSTRIES

Address : No. 8/3, Sukhram Estate, In Side - Rajesh Steel Line,
Opp. Khodiyar Police Chocky, Nr. Soni ni Chal, N.H. No. 8,
Rakhial, AHMEDABAD - 380 023. (Guj.) INDIA,
Mobile: +91 09998607579, 097255 33763,

E-mail : groupofharikrupa@gmail.com



Scan this QR in your smartphone

www.payalindustries.in

PI PAYAL
INDUSTRIES

PVC SUCTION HOSE PIPE, DIES
&
FORMER SPECIALIST



Former / Sizzar

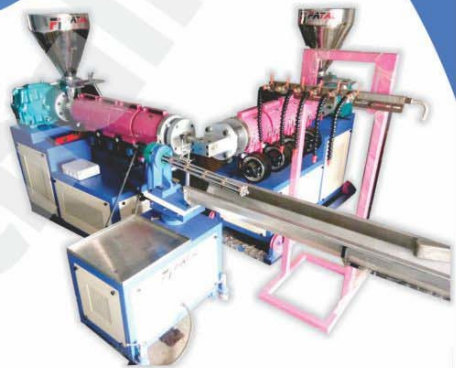

PVC Suction Hose Pipe Machine



Mixer Machine

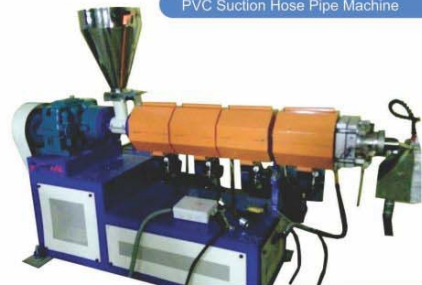

PVC Garden Pipe Machine

PI PAYAL
INDUSTRIES

19, Rajkamal Estate, Rakhial Road,
Soni' s Chal Rakhial, Ahmedabad - 26
Call .: +91 - 94268 20768, 93772 90236
E-mail .: info@payalindustries.in



Utkarsh Engineering

Manufacturer & Exporter Of:
Online Pipe Printing Machine



Online Pipe Printing Machine
With Bottom Printing Unit

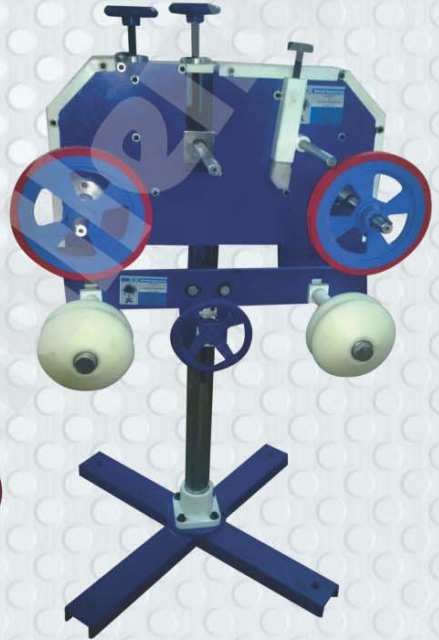

Online Pipe Printing Machine
Without Batch No



Online Pipe Printing Machine
With Batch No Provision



Utkarsh Engineering

41, Prathana Ind. Estate, B/h. Shakriba Party Plot,
Jamfalwadi Road, C.T.M., Ahmedabad-380026 (Guj.) INDIA
Phone : 079-25857327 Mob.: +91-94277 10035
E-mail : spc_utkarsh@yahoo.co.in



Shreeji Machine-
INTELLIGENT
BAG SEALING SOLUTIONS

Product Range :-

- ◆ Side Seal for Plain Bag Making Machine
- ◆ High Speed T-Shirt Bag Making Machine
- ◆ Side Seal Bag Making Machine
- ◆ Double Decker Bag Making Machine
- ◆ Bottom Seal Bag Making Machine
- ◆ High Speed T-Shirt with Conveyor Bag Making Machine



Side Seal for Plain Bag Making Machine



High Speed T-Shirt Bag Making Machine

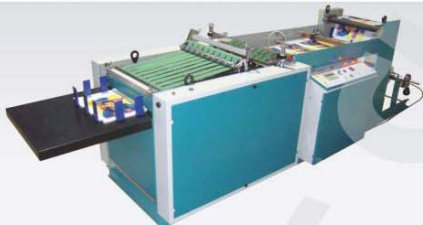

Side Seal Bag Making Machine



Double Decker Bag Making Machine



Bottom Seal Bag Making Machine



High Speed T-Shirt with Conveyor Bag Making Machine

SHREEJI MACHINE

Manufactures of Automatic High Speed Microprocessor Based Plastic Bags Making Machine

1-A, Nakoda Estate, Opp. Panorama Chowdi, Old.Halol-Kotal Highway, Village - Duniya,

Tal. : Halol, Dist. : PANCHMAHAL - 389350 (Gujarat) INDIA ,

Mob. : Kamlesh Mistry : 97236 10618, Nayan Mistry +91 99249 23308

E-mail : info@shreejimachinery.com, shreejihalol@gmail.com

Web : www.shreejimachinery.com



Website



Vertical Screw Type Plastic Injection
Moulding Machine



Direct Locking Vertical Injection
Moulding M/c

Mfg. By :

PRAMUKH MANUFACTURE

Office : 2/3 Gokulnagar, Gokuldharm Road, B/h. Nirav Com. Complex, Rajkot - 360 004, GUJARAT
Factory : Survey No.45, Shop No. 48,49,50, Shree Vallabh Estate, Nr. National Cotton, Opp. Panch
Pipla Estate, Shapar Road, Shapar (Veraval), Dist. Rajkot, Gujarat, INDIA

Ph : +91-281-2311731 **Cell :** +91-94277 25460, +91-94287 90025, +91-9924163127

E-mail : pramukhmanufacture@gmail.com

Web : www.mouldingmachine.in



PRAMUKH
MANUFACTURE



Roll Wrapping Machine



Trim Winder Machine



Box Wrapping Machine



Core Cutter

All Kind of Rotogravure Printing Machine, Slitting Machine, Blown Film Extrusion Machine, Printing and Textile Printing Machinery Parts & Precision Works



CHAMUNDA Engineering Works

Specialist in : All Type of Roller and Precision Works

Address : Plot No 1/4112, G.I.D.C. Vatva Phase-4, B/h. Nirma, Nr Nikatube Chokdi, Vatva, AHMEDABAD - 382 445 (Gujarat) INDIA

Phone : +91-79 - 25842550 Mobile : +91 98243 10199, 9924164954

E-mail : cewctm@yahoo.in Web : www.chamundaengworks.in

Product Range Of C.E.W

- Abrasive Machine Rollers
- Air Shaft
- Biscuit Machine Rollers
- Brush Rollers
- Ceramic Cladding Roller
- Chilling Rollers
- Conveyor Machine Roller
- Crook Roller
- Fabric Cutting Machine Roller
- Food Grade Roller
- Gudget Machine Roller
- Guide Roller
- Hard Chrome Plating
- Heat & Press Roller
- Hitter Roller
- Mirror Finish H.P. Roller
- Molding Parts
- Non Woven Sack Machine Roller
- Offset Printing Roller
- Paper Mill Rollers
- Pharmaceutical Machine Roller
- Pin Filled Copper Roller
- Plastic Machine Roller
- Plywood Machine Rollers
- Rewinder & Unrewinder Shaft
- Roto Gravure Printing Rollers
- S.S. Cladding Roller
- Screw Roll With Nut
- Solvent base Lamination Rollers
- Sp. Pin Filled Roller (Perforation)





Mould of thoughts are
Molding you
Ceaselessly

DEV PLASTOTECH Has been founded and headed by Visionary technocrat, Mr Bharat Mistry, an Electrical Engineer, award winner performer, had finished business management in 1992, who is having vast and truly professional experience in Plastics machines Building Industry, of more than 25 years, possessing deep knowledge of Engineering practices, standards and automatic system oriented work culture. We have a dedicated team which offers Quality Products and Services to its customers.

Our Products

- ▶ Bi Axial Machine ▶ Rock N Roll Open Flame Machine
- ▶ Single Arm Bi Axial ▶ Pulveriser
- ▶ Extruder ▶ High Speed Mixer ▶ Grinder



DEV
PLASTOTECH

Leading Manufacturer & Exporter of Plastic Roto
Molding Machines, Moulds and Accessories.

HO & WORKS: Plot no. 19, NK-2 Industrial Park, Bakrol to Dhamatwan Road, Village: Bakrol, Dist : Ahmedabad, Gujrat, India.
Phone: 9979056386, 9429919386, 9574971239 • E-mail: devplastotechindia@gmail.com, info@devplastotechindia.com,
export@devplastotechindia.com • Website: www.devplastotechindia.com, www.biaxialmachines.com, www.rotationalmoulds.com

All Kind of Printing and Textile Printing. Rotogravure Printing Machine,
Blown Film Extrusion Machine, Slitting Machine, Machinery Parts & Precision Works

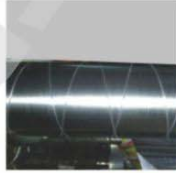
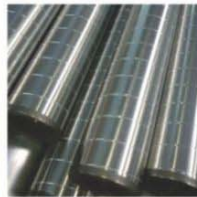
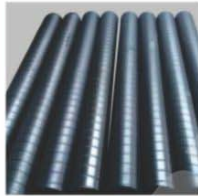
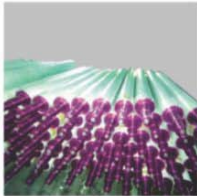

Vahanwati Engineering Works
31, Mahadev Estate, Part-3, B/h. Ramol Police Station,
CTM Ramol Road, Ahmedabad-380026 (Guj.) INDIA.
Mo : +91-9601876248,99099 05197
E-mail : vahanvati8586@gmail.com
Web : www.vahanwatiengineeringworks.in

**Bag Making &
Packaging Machine Manufacturers**

Product Rang :

- BAG MAKING MACHINERY
- PAPER BAG MAKING MACHINE
- CARRY BAG MAKING MACHINE
- MULCH FILM PUNCHING MACHINE
- POUCH MAKING MACHINE
- THREE SIDE SEAL POUCH PACKING MACHINE



MULCH FILM PUNCHING
MACHINE



SIDE SEALING MACHINE



POUCH MAKING MACHINE



PAPER BAG MAKING
MACHINE



DOUBLE DECKER
CUTTING SEALING MACHINE

DND MACHINERY

Address : Factory;Shed no-29,Somnath Ind Park,B/h Abhishree
Ind Park,Near G.V.M.M.Odhav,AHMEDABAD-382415 Gujarat (INDIA).

Mobile : +91 78782 54733,

E-mail : info@dndmachinery.com, dndmachinery@gmail.com,
sales@dndmachinery.com.

Website : www.dndmachinery.com



Website

Quality Products

Our Product Range

- » Hydraulic Bale Press For FIBC (Jumbo Bag)
- » Hydraulic Bale press 40 to 150 Ton
- » Hydraulic Cheese Pipe Straighter
- » **Hydraulic Bale Press For Waste**
- » Bobbin Cleaning Machine
- » Manual Printing (up to 4 Colours)
- » Gear Box Cooling For Tap Plant Hot Air Dryer Granules
- » Online Reforming (Fabric Inspection) Machine
- » Perforation Unit For Online Printing Machine
- » Surface Winder For Printing Machine & Lamination Plant
- » Online Gusseling Unit
- » Mixing Machine For Row Material (Granules)
- » Unwinding Unit & Rewinding Unit with Web Guiding System
- » Power Saving Blowers & All Accessories for Raffia Industries



Hydraulic Bale Press (40 to 150 Ton)



Hydraulic Bale Press For FIBC (Jumbo Bag)



Hydraulic Bale Press For Waste



Bobbin Cleaning Machine



Hydraulic Cheese Pipe Straighter



Perforation Unit



Hot Air Dryer



Granule Mixing Machine



Fabric Rewinding Machine



Surface Rewinder



Manual Printing Machine (up to 4 color)



Unwinding Unit



SAR MACHINES PVT. LTD.
SAR INDUSTRIES
Solution Provider for Woven Sack Industries

SAR INDUSTRIES : 9 & 11, K.P Industrial Estate, Gatrad-Bakrol Road, Village:Gatrad, Taluka : Daskroi,
Dist: Ahmedabad - 382430 (Gujarat) INDIA Cell :+91 96620 43526, 96620 43548 Tele Fax :+91-74 0501 2011
E-mail : sarindustries2011@gmail.com Website: www.sarindustries.com

SAR MACHINES PVT. LTD. : 135, Pushpak Industrial Estate, Nikatube Compound, Phase-1, G.I.D.C. Vatva,
Ahmedabad - 382 445 (Gujarat) INDIA Cell :+91 93761 86513, +91 93761 86526 Tele Fax :+91 74 0501 2011
E-mail : sarmachinespvtttd@gmail.com Website : www.sarindustries.com



INDIA PLASTIC CHALLENGE

The Plastic Challenge only

Bi-monthly Plastic News Magazine
A MARKET LEADER IN PLASTIC INDUSTRIES LATEST...

Free Distribution In All Leading Global Exhibition Of Plastic

Every month approx 1,00,000 plus parties emails.

we distribute around 8,000 to 10,000 copies of our magazine in every event.

Social Media Advertisement like ...

and many more.

Date: 3rd to 6th, August, 2018
Venue: Hitex Exhibition Centre, Hyderabad, INDIA

5th Edition

SRI LANKA
AUGUST
10 -12, 2018
COLOMBO

Date: 10th to 12th, August, 2018
Venue: Bmich Colombo Sri lanka

2nd Edition

SOUTH AFRICA
NOVEMBER
13 - 15, 2018
JOHANNESBURG

Date: 13th to 15th, November, 2018
Venue: GCC Johannesburg South Africa

Date: 30th November to 3rd, December 2018
Venue: Eco Park Exhibition Ground, Kolkata, INDIA

PLAST SHOW
16 DECEMBER 2018
19 RAJKOT

Date: 16th to 19th, December, 2018
Venue: Nsic Ground AJI GIDC, Rajkot Guj INDIA

Date: 17th to 20th, January, 2019
Venue: Bombay Exhibition Center, Goregaon East Mumbai, INDIA

Date: 28th February to 4th, March 2019
Venue: India Expo Centre, Greater Noida, Delhi-NCR INDIA

Date: 5th to 8th, March, 2019
Venue: Pragati Maidan New Delhi, INDIA

Launching Edition

NIGERIA
MARCH
19-21, 2019
Lagos

Date: 19th to 21th, March, 2019
Venue: Landmark Center Lagos Nigeria

Special Offer
Rate Inside Page

Book Your Advertisement At Forthcoming PLASTIC EXHIBITIONS

1 Time Full Page	13,000 Only
6 Time Full Page	54,000 Only
12 Time Full Page	96,000 Only

THE ORIENT SP-AGE PUBLICATIONS
C - 304, "RICHI HOUSE"
Opp, Swaminarayan Temple,
Nr, Maninagar Rly Crossing,
Maninagar, AHMEDABAD - 380008
(Gujarat) INDIA
Ph. +91 79 25463623
Email.: ipcnews2@gmail.com
Website.: www.indiaplast.in,
www.plasticchallenge.in

Mobile : +91 98980 87920, 93740 66920,

Disclaimer : The information furnished has been collected from varied sources, and hence, is subject to change. To confirm the show schedule kindly contact the show organiser.

COMPLAST KENYA 2018

6th edition of COMPLAST 2018, the great show of plastics shall be performed in Nairobi, Kenya,



Complast Kenya is a 3 day event being held from 13th July to 15th July 2018 at the Kenyatta International Convention Centre Nairobi, Kenya. This event showcases products like Raw materials, polymers & resins, intermediates, blends & alloys, composites, testing equipment, software solutions and much more etc. in the Plastic & Plastic Products industry. Since last 10 years Kenya's growth is in top gear and big players and industrialist have taken serious interest in investment and offered all kind of technological help. Kenya Plast is a trade fair for plastics products and takes place in Nairobi. This exhibition is communication and information platform in the industry and offers the exhibiting companies the opportunity to present to an audience of experts here. Visitors can find in depth and comprehensive information here about the latest developments, trends, products and services in various fields. Kenya Plast is a 3 day event being held from 13th June to the 15th July. 2018 at the Kenyatta International Conference Centre (KICC) in Nairobi, Kenya. This event showcases products like promote the international ties between Kenya in particular and India and is a trade fair that witnesses the presence of products from the Indian industry and includes Indian



goods and services, industrial goods, consumer goods and durables and much more to add to the list etc. in the Plastic & Plastic Products industry

The event shall become leading platform to showcase the latest machineries and global manufacturing trends. It will

provide the regional plastic processors an opportunity to source the complete range of plastic converting requirements from raw material, additives, molds and machinery.

Kenya has a warm and humid tropical climate on its Indian Ocean coastline. The



climate is cooler in the savannah grasslands around the capital city, Nairobi; especially those closer to Mount Kenya, which has snow permanently on its peaks. Kenya is known for its world class athletes in track and field and rugby. Thanks to its diverse climate and geography, expansive wildlife reserves and national parks such as the East and West Tsavo National Park, Amboseli National Park, Maasai Mara, Lake Nakuru National Park, Aberdares National Park and white sand beaches at the Coastal region, Kenya is home to the modern safari and has several world heritage sites such as Lamu and a number of beaches, including in Diani, Bamburi and Kilifi, where international yachting competitions are held every year.

Industry and manufacturing is the smallest sector, accounting for 16% of GDP. The service, industry and manufacturing sectors only employ 25% of the labour force but contribute 75% of GDP[101] Kenya also exports textiles worth over \$400million under Agoa.

- Editor
Rajesh Gohil



The Magazine For
Plastic Industries
The Orient SP-Age Publications

: Head Office :
304, Richi House, Nr. Rly. Crossing,
Maninagar, AHMEDABAD-380008
Gujarat-INDIA.
Ph.: +91 79 2546 3623
Mail us: ipcnews2@gmail.com

URL: www.plasticchallenge.in
www.indiaplast.in

Publisher
R. R. Shukla

Editor
Mr. Rajesh Gohil

CEO
Mr. J. Radheshyam

Business Relation

Mr. N. K. Shukla
+91 9898 087 920
Mr. Vinod Kumar
+91 9275 129 533

Executive - Web Marketing

www.indiaplast.in

Circulation Executive
Mr. Vijay
Mr. Janardan
Ms. Harsha Trivedi

Online Partner
www.industrialsexpress.in
www.plasticchallenge.in

Design & Layout
Rishabh Bajpai

Published by
The Orient SP-Age Publications

Printed at
Pradipam Offset

Articles & advertisement published & printed in The Orient SP-Age Publications are included after best knowledge and ability. Articles published in our magazine are based on material data, detail and description provided to us or collected by us from various sources. However printer / publisher / editors are not responsible morally or legally for any act of addition / deletion / correction alteration / editing or censoring. We publish this magazine in the interest of our business associates exhibition organizers advertisers, subscribers with personal attendance. Any type of claims or legal issues are subject to AHMEDABAD jurisdiction.

Think & Make Big With BENGAL

PLAST BENGAL EVOLUTION DESTINATION 2018

Netaji Indoor Stadium & Khudiram Anushilan Kendra
Kolkata • West Bengal • India
13th - 15th July 2018 • 11:00 Hrs - 19:00 Hrs

Supported By:

 **INDIA-CHINA CHAMBER OF
COMMERCE & INDUSTRY**
印度-中国工商商会



Media Partners



+91-8557868553

plastbengal@gmail.com

www.plastbengal.com

Organised By:



Global Bengal Committee

SHRISTI MACHINERIES PVT.LTD.

OUR PRODUCT RANGE

- Hydraulic Balepress 10 to 200 Ton.
- Hydraulic Cheese Pipe Straighter.
- Waste Hydraulic Bale Press
- Bobbin Cleaning Machine
- Manual Printing (up to 6 Colours).
- Online Reforming (Fabric Inspection) Machine.
- Perforation Unit For Online Printing Machine
- Surface Winder for Printing Machine & Lamination Plant.
- Power Saving Blowers.
- Mixing Machine.
- Unwinding Unit & Rewinding Unit with web Guiding System
- Hot Air Dryer & All Accessories for Raffia Industries.
- Waste Recycling Machine

INDIA'S BEST QUALITY



Hydraulic Bale Press
10 ton to 100 tons



Jumbo Bale Press
80 tons to 200 tons



Waste Bale Press
Paper Pet & Plastics



Hydraulic Cheese Pipe Straighter



Granule Mixer with Dryer



Roll to Roll
Printing Machine



Twist Gusset



Waste Recycling Machine



Surface Rewinder



Fabric Rewinding Machine
20 inch to 150 inch



Bag Cutting Machine

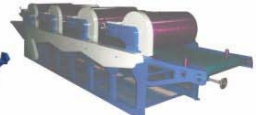

Manual Printing Machine



Bobbin Cleaning Machine



Micro Perforation Unit



Hot Air Dryer

*Solution Provider
for woven Sack Industries*



SHRISTI MACHINERIES PVT.LTD.

Factory : 48, Siddhpura Estate, Phase - IV, G.I.D.C., Vatva, Ahmedabad (Gujarat) INDIA
 Telefax : 079 - 25893682, Cell: 09725450627, 09725000792, 09601253875 ,09998801682
 E-mail : info@shristiengineers.com, vinodpandey60@yahoo.com
 marketing@shristiengineers.com Website : www.shristiengineers.com

2018
Rajkot,
Saurashtra

Organizing & Associated by :



Rajkot Plastic
Manufacturer's Association

PLAST

SHOW - SAURASHTRA

India's Prime
Exhibition on
Plastic Industries
& Technology

16,17,18,19 December-2018
Race Course Ground, Rajkot-Gujarat, INDIA

Supported by :



Co.Organized by:



More Details :: 094262 49072 | 063534 39877 | E.mail : sunlineinfotech@gmail.com

www.indiaplastshow.com



Vacuum Sizing Tank



Twin Screw Extrusion Line for PVC & UPVC



Twin Screw Extruder



Planetary Pipe Cutting Machine for PVC & HDPE



Single Screw Extrusion lines for PE



Strand Pelletizing Line

Manufacturers of Single / Twin Screw Extrusion Lines for PVC, uPVC, cPVC, HDPE and PPR tubes, Material handling systems



RCV ENGINEERING (INDIA) PVT. LTD

Address : Plot No. 154, Tribhuvan Ind. Estate, Nr. Road No. 11, G.I.D.C Kathwada, AHMEDABAD - 382 430, (Gujarat) INDIA

Ph.: 079 - 2287 0187 | Cell : +91-99099 00772, 95100 10091

E-mail : info@rcvindia.com, sales@rcvindia.com | Visit Us : www.rcvindia.com

Like us on: www.facebook.com/rcveng



EXPLORE NEW AVENUES OF GROWTH

at

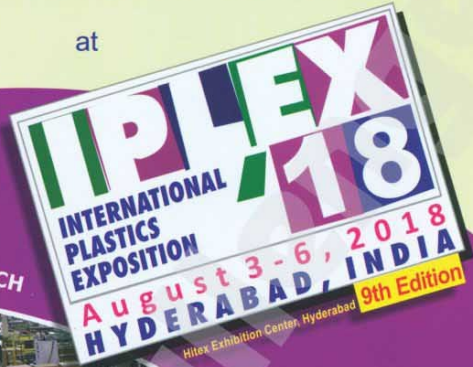

OPPORTUNITIES WITHIN REACH

Hitex Exhibition Center, Hyderabad



Once Again At Hyderabad

Organized By



Supported By



304, 3rd floor Raghava ratna Tower,
chirag ali lane, Abids, Hyderabad, Telangana 500001 INDIA
Tel : 040-23203191, 040-2320211
E-mail : iplex18hyd@gmail.com Website : www.iplex.com



Plastitec Machinery



Lab Two Roll Mill



Lab Hydraulic Press



Lab Hydraulic Press



Strand Pelletizer Machine



Single Screw Extruder



Single Screw Extruder (2)



Conical Screw And Barrel



Scrap Grinder Machine



Air Face Pelletizing System



Air Face Pelletizing System



Air Face Pelletizer



Under Water Pelletizer



Vibrator Machine



PVC Mixer Blade Set



Conical Extruder Gear Pinion Set



Mixer Aspiration System



Plastitec Machinery

We understand your need

Address : Plastitec Machinery, A-2/3911, C/o-asmi Pump Ind,

Near Naroto Unit-2, Phase-4, G.I.D.C Vatva, Ahmedabad - 382445.

Phone : +91-9033484045, +91-6351155020

Email : plastitecsales@gmail.com

**Manufacturer & Exporter of
Rotomoulding Machinery & Moulds,
Extrusion Plants & its Auxiliary Equipments**



BI - AXIAL MACHINE
[1000 ltrs 4 Mould Swing on Single Arm]



Agglomerator



Pulveriser



Recycling Plant



NAVDURGA ENGINEERS

82, Panchratna Industrial Estate, B/h. Zaveri Estate,
Singarva-Kathwada Road, Kathwada, AHMEDABAD-382 430 (Gujarat) INDIA
Ph.: +91 79 65411422 Cell.: +91 98795 41422 / 94263 44688 / 94267 66456
E-mail: info@rotomouldingmachine.com, panchaln11@live.com
Web: www.rotomouldingmachine.com

Our Sister Concern :
MAHEK ROTOMECH



Macplast

Extrusion Technik

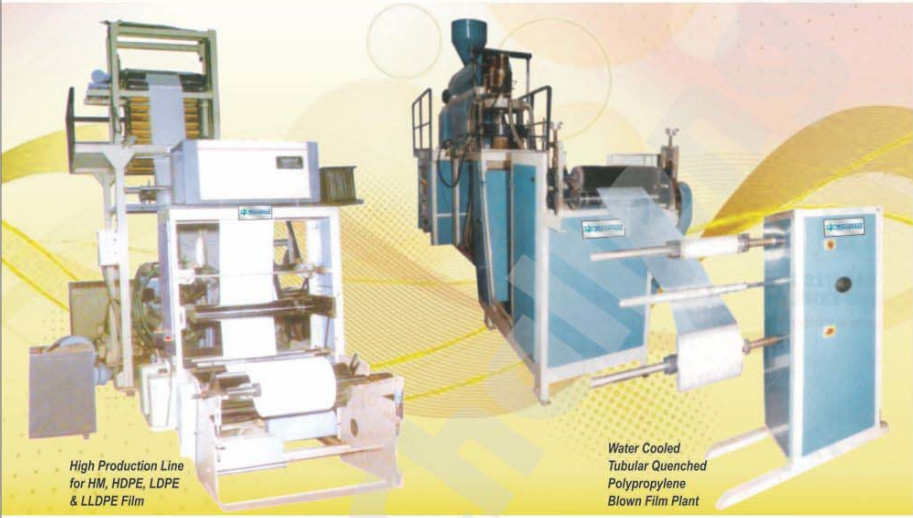

High Production Line
for HM, HDPE, LDPE
& LLDPE Film

Water Cooled
Tubular Quenched
Polypropylene
Blown Film Plant



PP - HDPE - Box Strapping Plant

Synthetic Spring Plant (Sutli Plant)

Our Range of Product

- Multi Layer Film Plant
- Two / Three Layer PPTQ Blown Film Plant
- Win Head Mono Layer Blown Film Plant
- Sutli Plants
- Box Strapping Plants
- LDPE Kiswa Pipe Plants
- HDPE Pipe Plants
- Reprocess Plants
- Woven Sakes Tape Plant

Regd. Office & Works

49, Shreenathji Estate, Nr. Panna Estate, B/h. B.O.C.
Gases, Rakhial, AHMEDABAD 380 021 (Guj.) INDIA.

Phone : (F) 079-22746802

E-mail : macplastbp@hotmail.com / macplastbp@rediffmail.com

Web : www.macplastextrusionstechnik.com/

Supported by:



Organised by:



Supported by:



Indplas '18

Promote • Progress • Prosper • Profit

8th INTERNATIONAL EXHIBITION ON PLASTICS

November 30th - December 3rd, 2018
Eco Park Exhibition Ground, Kolkata, India

LET'S MOULD THE FUTURE

TIME IS LESS!

Limited Stalls Available

An exhibition on Plastics which cannot be missed!

Book immediately before its too late
on : www.indplas.in

Diamond Sponsors:



Platinum Sponsor:



Gold Sponsors:



Think it. Linc it.



Silver Sponsors:



For Further Details, Please Contact:

INDIAN PLASTICS FEDERATION (CIN: U91110WB1959NPL024140)
8B, Royd Street, Kolkata 700016, India

Phone: +91 33 2217 5699 / 5700 / 6004 / 6005 | E-mail: exhibition@indplas.in | Website: www.indplas.in / www.ipfindia.org

Ashok Jajodia, Chairman, INDPLAS '18, Organising Committee

Mobile: +91 09310 90756 | Email: chairman@indplas.in



@ipf_india | IPF INDPLAS | indplas_ipf | www.facebook.com/indianplasticsfederation | www.youtube.com/IPFINDIA



by:
plastemart.com

Packaging Equipment Bring Performance Improvements

Plasti

Performance improvements apply to packages, as well as to packaging equipment. This article will show packaging equipment that improve their efficiency to help give your entire production line a boost.

*InvisiPac HM25c Tank-Free Hot Melt Application System

A compact design of the Graco InvisiPac HM25c Tank-Free hot melt application system integrates easily into existing packaging lines. The benefit of this on-demand system is the elimination of adhesive char and the inevitable downtime for maintenance. Graco InvisiPac uses melting chambers that have a greater melting surface area versus the typical tank-based systems or reservoirs with melting fins. This means the equipment can melt the adhesive fast and dispense it immediately so waxes in the adhesive don't evaporate, which saves on material costs.

Since the adhesive doesn't sit in a tank and char, frequent downtime for cleaning out plugged up nozzles is a thing of the past. Operators use InvisiPac hot melt systems can go over a year or more without changing settings or even touching the system, depending on the application. Additionally, the InvisiPac HM25c is equipped with LineSite remote monitoring, so production managers can receive real-time performance reports and notifications to make sure their packaging lines keep producing.

*USI-Sonixs Side-Seal Strapping System

The USI-Sonixs side-seal strapping system uses the Sonixs ultrasonic sealing system to create strong seals with no smoke, no warm up time and low energy use.

With a long system life, low operating costs and affordable replacement parts, the Sonixs strapping head can secure loads up to 1.8

meters wide (almost 6 feet) by 2.75 meters high (9 feet). It applies tension of 450 lbs to plastic straps (polypropylene or polyethylene) with up to 750 lbs breaking strength.

Available with operator-initiated or automatic cycling, the unitizer is often integrated into a conveyor line and indexes to meet the side of the load to be secured. It offers optional pallet void Feed, Underfeed Or Automatic through/underfeed.

*MK-U Series Inkjet Printer

The updated MK-U Series continuous inkjet printer has a unique auto-cleaning function that uses 70% less solvent yet ensures a deep cleaning. The system uses high-pressure pulsed jets of solvent to clean the ink path, nozzle, electrode plates and gutter all at once. No printhead disassembly or manual cleaning is needed.

Benefit of this system is using less fluids for lower cleaning costs. Also, minimizing exposure to chemicals is safer for employees. It is more efficient, too, because an operator can press the "clean" button and do other tasks while the system does the cleaning automatically.

*2.5D Cobot Packaging

Generally, robotics offer a high level of production flexibility due to their ability to be reprogrammed for a new task. Collaborative robots take that up a notch by also operating more flexibly in a plant environment along with fellow human workers. Universal Robots will be demonstrating how its cobot arms have been used by integrator Robotic Vision Technologies to pick-rotate-and-place parts/products off a conveyor in 2.5D.

What 2.5D means is a combination of 3-dimensional position (X, Y and Z) and 1-dimensional rotation (R). Essentially, this is a standard 2D solution with depth information. The robot can just as easily find pieces that are stacked two to three high.





INDIAPLAST

28 FEB-4 MAR 2019

India Expo Centre, Greater Noida, Delhi NCR

in association with



AN EVOLVED PLASTICS EXHIBITION

By the Industry for the Industry



PLATINUM SPONSOR



GOLD SPONSOR



SILVER SPONSOR



Jointly organized by



M : +91 99867 79771
www.indiaplast.org

Organised by:



POWERING PROGRESS THROUGH PLASTICS



11th PLASTIVISION INDIA 2020

THU FRI SAT SUN MON
JAN -16-17-18-19-20 MUMBAI

INTERNATIONAL PLASTICS EXHIBITION & CONFERENCE
Bombay Exhibition Centre, NESCO, Goregaon (East), Mumbai - 400 063.

Key Highlights of Plastivision India 2020

100000
sq mtr

1500+
exhibitors

25+
countries



Organized by:

THE ALL INDIA PLASTICS MANUFACTURERS' ASSOCIATION

AIPMA House, A - 52, Street No. 1, MIDC, Marol, Andheri (E), Mumbai - 400 093, INDIA.

T: +91 22 6777 8846 / 47 / 48 / 49 | E: sanjeevani@plastivision.org | W: www.plastivision.org



POWERING PROGRESS THROUGH PLASTICS

R.D.MOULD



Specialist in Plastic Spoon Mould

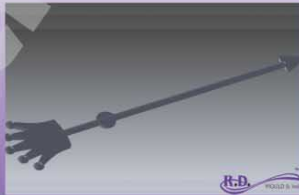

R.D.MOULD

Designer Spoon Mould | Ice-cream Spoon Mould
Plastic Fork Mould | Plastic Knife Mould
Plastic Spoon Mould | Plastic Stirrer Mould

Registered Office :

34, Arihant Estate, Nr. Nalanda Estate & Sabri Hotel,
Odhav Ring Road Circle, AHMEDABAD , Gujarat - 382415 INDIA
Contact Person : Mr. Rajesh Dudhat Mobile : +91 93777 61062
Email : spoonmould@gmail.com Website : rdplasticspoonmould.com



by
plastemart.com

Packaging Equipment Bring Performance Improvements

Performance improvements apply to packages, as well as to packaging equipment. This article will show packaging equipment that improve their efficiency to help give your entire production line a boost.

***InvisiPac HM25c Tank-Free Hot Melt Application System**

A compact design of the Graco InvisiPac HM25c Tank-Free hot melt application system integrates easily into existing packaging lines. The benefit of this on-demand system is the elimination of adhesive char and the inevitable downtime for maintenance. Graco InvisiPac uses melting chambers that have a greater melting surface area versus the typical tank-based systems or reservoirs with melting fins. This means the equipment can melt the adhesive fast and dispense it immediately so waxes in the adhesive don't evaporate, which saves on material costs.

Since the adhesive doesn't sit in a tank and char, frequent downtime for cleaning out plugged up nozzles is a thing of the past.



Operators use InvisiPac hot melt systems can go over a year or more without changing settings or even touching the system, depending on the application. Additionally, the InvisiPac HM25c is equipped with LineSite remote monitoring, so production managers can receive real-time performance reports and notifications to make sure their packaging lines keep producing.

***USI-Sonix Side-Seal Strapping System**

The USI-Sonix side-seal strapping system uses the Sonix ultrasonic sealing system to

create strong seals with no smoke, no warm up time and low energy use.

With a long system life, low operating costs and affordable replacement parts, the Sonix strapping head can secure loads up to 1.8 meters wide (almost 6 feet) by 2.75 meters high (9 feet). It applies tension of 450 lbs to plastic straps (polypropylene or polyethylene) with up to 750 lbs breaking strength.

Available with operator-initiated or automatic cycling, the utilizer is often integrated into a conveyor line and indexes to meet the side of the load to be secured. It offers optional pallet void feed, underfeed or automatic through/underfeed.

***MK-U Series Inkjet Printer**

The updated MK-U Series continuous inkjet printer has a unique auto-cleaning function that uses 70% less solvent yet ensures a deep cleaning. The system uses high-pressure pulsed jets of solvent to clean the ink path, nozzle, electrode plates and gutter all at once. No printhead disassembly or manual cleaning is needed. Benefit of this system is using less fluids for lower cleaning costs. Also, minimizing exposure to chemicals is safer for employees. It is more efficient, too, because an operator can press the "clean" button and do other tasks while the system does the cleaning automatically.

***2.5D Cobot Packaging**

Generally, robotics offer a high level of production flexibility due to their ability to be reprogrammed for a new task. Collaborative robots take that up a notch by also operating more flexibly in a plant environment along with fellow human workers. Universal Robots will be demonstrating how its cobot arms have been used by integrator Robotic Vision Technologies to pick-rotate-and-place parts/products off a conveyor in 2.5D.

What 2.5D means is a combination of 3-dimensional position (X, Y and Z) and 1-dimensional rotation (rZ). Essentially, this is a standard 2D solution with depth information. The robot can just as easily find pieces that are stacked two to three high.





IT'S TIME YOU
EXPLORE SRI LANKA
PLASTICS MARKET... TOO!

BOOK YOUR SPACE NOW

International Plastics Exhibition



10 - 12 AUGUST, 2018
BMICH I COLOMBO



150
EXHIBITORS



15
COUNTRIES



LIVE
DEMOS

For Space Book contact

Narendar Bafna : +91 99529 66752

Vijay. N : +91 97890 95249

FiÄöX öç† éJîNî||†äJiöX®êç†→Äã´ EÄiÄö† ßßß→NçäéJiöX®êç→

Organized by



Co organised by



The Plastics & Rubber
Institute of Sri Lanka

Supported by



The Plastics Export
Promotion Council

Platinum Sponsor by



The Spoon King



Kamal[®]
MOULDS

**Mfg. Of : All Kinds Of
Plastic Moulds & Dies**



Director
Kamal Moulds



ABOUT US:

Established in the year 1991, we, "**Kamal Moulds**", are a coveted manufacturer and supplier of Dies and Moulds. We offer products such as Mare Complete Article, Mould Picture and Plastic Mould. Owing to their high quality, durability and domestic purposes. We manufacture our products utilizing tested raw material and modern machines. These raw material are procured from trustworthy vendors. flexibility, these products are used for commercial

Our organization has established itself with firm determination and great dedication. We have a well-managed infrastructure that has various advanced departments. These departments cater to innumerable needs of the customers and deliver an unmatched range of products. Our organization proudly meets the requirements of our clients based in East Asia, South East Asia, Middle East and the Indian Subcontinent. Also, for the convenience of our clients, we facilitate them with easy payment modes and terms. Our organization delivers products on time and in a flawless condition. We have been certified with **ISO 9001** for total quality management.

We are successfully achieving the set targets on time, under the able guidance of our mentor "**Mr. Mafatal M. Paradia**". His vast knowledge and expertise are the sunbeams of bright prospects that lighten up our organization.



About Jailaxmi Engineering Corporation

After making a humble beginning in 1980, Jailaxmi has become a trusted name in plastic processing industry and reached well throughout India with hundreds of plants installations. We provide an ultimate and customized solution taking into consideration the ease of operation by operators and by the processors in day to day operation.

Mr. Harshadbhai D. Patel, M.D. in the organization have taken a lead from **Late Mr. Dayalbhai R. Patel** a founder of **Jailaxmi Engineering Corporation** to continue with utmost dedication, discipline and sincerity, so as to provide a better than best range of products which are user friendly and have latest control techniques to

(in our plants the future technology is up-to-date). The set-up is in accordance with the changing market trends and we are constantly upgrading the working facilities and equipment to serve our customers better.

The company entered into development of various extrusion systems and delivered its first HM/HDPE Film Plant in 1981. And since then, never looked back, continuing to add one after the another extrusion line into its product range quality. **Jailaxmi Engineering Corporation** feels proud to claim ourselves as market leaders in the field of Plastic Machinery manufacturers. You will find our presence all over India. We are trust worthy name amongst the hundreds of customers who became



become cost efficient and successful with high returns on investment, by **lowest running cost of plant in years of use.**

The company is situated in Navsari City (South Gujarat, India).

About Navsari :

Navsari is birth place of Jamshedji Tata, the founder of TATA Group. Navsari is the town of Dadabhai Navroji, first Parliamentarian in British Parliament. The historical place DANDI is located at the outskirts of Navsari from where Mahatma Gandhi began **Salt agitation against British Empire.** Navsari is located between Mumbai and Ahmedabad, which is 30 km from Surat and 80 km from Vapi Industrial Zone.

Having latest manufacturing facilities with most modern and advanced machine tools

successful entrepreneurs using machinery manufactured by us.

We are not only the machine manufacturers but we are technocrats who understand requirements of our customer.

We provide solutions to our customers as per their requirement. We provide Custom made as well as Tailor made solutions to anything in plastic machinery manufacturing to convert their inputs & money into Financial gain with rise in every year.

We are very well known for our after sales service in India.

We are a company who believes in continuous development and research. We keep our eyes in the latest technology available in the world market.



Jailaxmi Engineering Corporation

MAKERS OF PLASTIC EXTRUSION PLANTS

C-30, Udyognagar, Navsari - 396 445, Gujarat, India. Ph : 02637 - 257028, 656228

www.jailaxmiindia.com, www.jecindia.in

Our Achievements



Manufacturer and Exporter

Call : +91-98252 64845

Laminator



Co-Extrusion with "T" die



Updated Technology with
 Zero wastage Co-Extrusion
 Lamination Plant



Celebrating
37th
year of success

Our Products

- › Extrusion Coating Lamination Plant
- › Co-Extrusion Coating Lamination Plant
- › LLDPE, HM-HDPE, LDPE Film Plant
- › AB & ABA Co-Extrusion Film Plants
- › Co-Extrusion Film Plants
- › PP TQ Film Plant
- › Plastic Film Making Plant
- › R-PVC / S-PVC Film Plant

JAILAXMI ENGINEERING CORPORATION
 C-30 Udyog Nagar, Navsari-396445
 Gujarat (INDIA)

www.jailaxmiindia.com, www.jecindia.in
www.jailaxminvs.com,

Office
 +91-2637-257028
 +91-2637-656228

Email
jailaxminvs@yahoo.co.in
jailaxmi1980@gmail.com





NARNARAYANDEV ENGINEERING



Online Pipe Printing Machine

Manufacturing Of :

- ☀ Online Printing Machine
- ☀ Printing Wheel
- ☀ Silicon Rubber Wheel
- ☀ Doctor Blade
- ☀ Ink
- ☀ Reducer



NARNARAYANDEV ENGINEERING

Address : 2, Labh Ghar Society, Nr Swaminarayan Gurukul, Vastral,
AHMEDABAD - 282418 (Gujrat) INDIA

Mobile : +91-99984 88057 E-mail : nndengineering1186@gmail.com



Address

Chamunda's

Clamps are ideal for

- Plastic Machineries Manufacturing Industries
- Rotomould Industries • Mould Clamping

Mfg. & Exporter Toggle Action Clamp



Since 1986



Compact Clamps

Ideal for Lids, Door Closer & Ice Box



Holding Pressure 75 kg

Holding Pressure 75 kg

Holding Pressure 90 kg

Holding Pressure 125 kg

Horizontal Handle Clamp

PA-10TA Holding Pressure : 300 kg Heavy Duty Mold Hinge



Pull Action Clamp

PA-H Horizontal Handle Toggle Clamp

- Pipe Extrusion Plant
- Blow Film Plant
- Plastic Recycling Plant
- Heater-Cooler Mixture

PA-2H & 3H

PA-4H & 5H

pressure capacity from 100 kg to 3000 kgs.

T¹ BOLT

T² BOLT

M 12 to M 24

M 12 to M 20

Strap Clamp

M 12 to M 20

T¹ Nuts

M 10 to M 20

Flanged Nut

M 12 to M 24

TGP Series

Pull Back Clamps

Holding Pressure 100 kg to 500 kg

This model is ideal for Rotational Moulding



WORKS : Sabarmati Textile Estate, Nr. Vastupal Steel, Opp. G.S.T., New Ranip, Ahmedabad-382 480. (Guj.) India.
TELE/FAX : (O) 91-79-2752 2437, 6525 2278
(M) : 097244 02626, 098980 60737, 092274 42278
E-mail : clamp@chamundaequip.com
Web Site : www.chamundaequip.com



Work With Us For BETTER QUALITY BETTER SERVICE BETTER VALUE

mfrs World Class PLASTIC PROCESSING MACHINERY

Devikrupa Industries is One of The Leading and global manufacturer and exporter of extruder machines, screws and barrels for plastic processing machinery. We are having our in house manufacturing capabilities which facilitate prompt response at each stage of production. We are in the business of manufacturing Plastic Extrusion Machinery and Plastic Processing equipment, and have reached well throughout india by meeting the requirements entrepreneurs in industrial areas, in the prominent cities, and various development sectors in the country. Our products incorporate user-friendly operations and controls. Our product range includes P.V.C. film(Soft/Rigid/Shrink), PVC profile (For Wooden Pattern), Compounds (For all kind of compounds) and injection Moulding Screws.

Application



Twin Screw & Barrel



"Extruder Available in to 3 to 4 Weeks"

Extrusion Accessories

Extrusion Machine



DEVIKRUPA EXTRUSION

Head Office : Plot No.67/14, Road L-9, Nr.Abhyudaya Co-Op.Bank, Opp.Subham Extrusion Technic, Phase-1, G.I.D.C.,Vatva, AHMEDABAD - 382 445. (Gujarat) INDIA
Mobile : +91-94287 34532, 098259 23220 Phone : 079 - 40083831 (3 lines) Fax : 079 - 40083832
E-mail : info@devikrupaindustries.com, info@twinscrewbarrel.com
Web : www.devikrupaindustries.com, www.twinscrewbarrel.com



Scan This Code On Your Smart Phone

Hydraulic Sealing For :

follow us on your favorite social media sites

- > Injection Moulding M/c.
- > Blow Moulding M/c.
- > Plastic Processing M/c.



- Importers & Stockist of Halilite®, Kastas®, Tecnolan®, UHS, DHS, Valqua, DZ, TKS, NOV, Halite, Parker Which includes Rod Seal, Piston Seal.
- PTFE Back up - O Ring Gasket & Exclusive Items.
- DA Seal I Glydring - Step Seal I Rod Seal
- Guid Strip Roll Form & Ready Cut Rings from Bronze, Carbon, UHMW, FRPP
- Metal + PU - Metal + Rubber Plain - Excluder type DA17 type - DAL Wipers
- Imported O-Rings & O-Ring Boxes
- Cord - NBR Silicon Viton PU-PTFE
- Chevron Set - Canvas, NBR, Viton, PU, POM, PTFE
- Pneumatic Seal - EU Main Seal, PP Cushioning Seal, E4, Piston Seal, Wiper Seal and other Sealing items like Piston
- Coupling Elements equivalent to Lovjay, Rotex, & Others.
- Rotary Seal - TC Type Oil Seal, Spring Energised, PTFE Lip Seal etc.
- Dowty Seal, Copper Washer, NBR Bush
- Complete Kits for JCB, Tata, Hitachi, Komatsu, Wipro, L&T Etc.
- Replacement Spares for IR, CPT, KGK, KPC.
- PTFE, Glass Carbon, Maly Bronze Stock shapes & Machine Items
- Filled PTFE for Pharma, Auto, Electrical, Chemical, Construction etc.



Hiflon Polymers Industries
Plastic M/c Mfgrs (Hyd. & Pneumatic)

Address : 5/8/1, Dasrath, Estate, Nr. Revabhai Estate, C.T.M. Cross Road, AHMEDABAD - 380026, Gujarat, INDIA
Ph.: 079-25858345 **Mobile.:** +91-90330 58345, +91-94265 35480
E-mail : hiflon@hiflon.com
Web : www.hiflon.com

Plastic Machinery

Conical Twin-screw & Barrel

Single Screw Barrel

Sleeve Fitted Front Barrel

HSS Sleeve

Screw Barrel & Ancillaries

Twin Screw

Parallel Twin Screw & Barrel

Barrier Screw for HDPE & PP

Single Screw

Grooved Sleeve Barrel & Barrier Screw

Our Product Range:

- Conical Twin Screw & Barrel
- Barrier Screw
- Parallel Twin Screw & Barrel
- Maddoc Screw & Ancillaries
- Single Screw & Barrel

A. A. ENTERPRISE

B-52, Bandhan Society, Cadilla Road, Ghodasar, AHMEDABAD-380050 (Gujarat-INDIA)
 Ph.: (O) 079-2546 2545 | M.: +91 9898 241 416
 E mail: aaenterprises22@gmail.com | aaenterprise@rocketmail.com

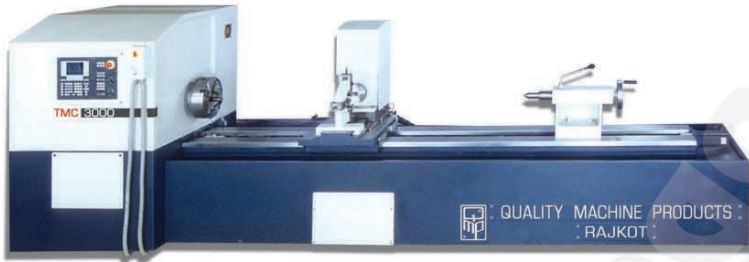

CNC Thread Milling



TMC



Model A



Model B



Model D



Model E

Mfg. & Exporters :

- CNC Turning Lathe
- Light & Heavy Duty Lathe
- Roll Turning Lathe
- S.P.M. Machines
- CNC/PLC
- Conventional Thread Milling Machine



Quality
Machine Products
Since 1970

Quality Machine Products

Factory : Plot No. G-1434, Phase - I, Road - D (7/B), Gate No. 2, GIDC Metoda,

Tal.: Lodhika, Dist.: Rajkot, Gujarat, INDIA

Tel: +91-2827-287 782, Mobile: Amit Chhaniara +91 98256 07407

Email : qmpindia@gmail.com Web : www.qmpindia.com



by:
plasternart.com

New Pouching and Cartoning Lines Get a Boost from Delta-Style Robot

Plasti

Single-serve 30-g pouches of powdered meal replacements for people on weight loss programs

have been flowing out of Medifast's headquarters facility at a brisk pace over the last few years

as demand for the clinically proven and popular products has been strong.

The new pouching and cartoning lines at Medifast get a boost from a delta-style robot.

Each of the new lines is anchored by a pouching system from KHS Bartelt as well as an end-load

cartoner from the same supplier. Uniformity in pouching equipment from one line to the next was

a big driver behind Medifast's choice of putting Bartelt equipment in both lines.

Accuracy of fill is also a key.

While pouching systems and cartoners on the two new lines are essentially the same as on systems Medifast has operated in the past, dramatically different is what's in between poucher

and cartoner: a continuous-motion delta style robotic system from Codian Robotics that uses

vacuum cups to pick laid-flat pouches two at a time from a Dorner conveyor and neatly stack them seven-high in collating buckets on the cartoner infeed.

Once two buckets have their full complement of pouches, they're advanced in the direction of

the cartoner and two new buckets move into place to be filled. The full buckets, meanwhile, index into the cartoner so that the seven-

count stacks of pouches can be pushed into a tuck-style paperboard carton.

Making this high-speed robotic transfer even more intriguing is that the robot's end-of-arm tooling rotates every other pouch. The powder tends to bunch up at the bottoms of the pouches so that you have a fatter bottom and a very thin top.

If you stack seven of them this way, you're looking at a stack that is very unstable, which naturally leads to handling problems and frequent jams on the cartoner.

By alternating the pouches this way, we have a much more uniform, repeatable, and stable stack.

While KHS Bartelt's choice for robotic hardware was Codian, the robotic infeed system and the robot itself are controlled by the five-axis cartoner's Bosch Rexroth IndraMotion MLC motion

logic control platform, which is similar to the controller governing the upstream eight-axis poucher.

This control platform delivers all the motion and robot control capabilities needed for what a controls geek might call "multiaxis path interpolation in space." The control platform

so accurately synchronizes the movement of the delta style robot to the movement of the pouches on the Dorner conveyor that the robot "knows" exactly where in space to go each time it needs to pick a pouch—even though the pouches are moving targets.

The Bosch Rexroth platform features a full software library of ready-to-use kinematics for robotics applications and supports fast set-up configuration using onscreen dialog boxes.

The Rexroth IndraControl L65 is a powerful, scalable unit featuring a compact design and integrated standard interfaces, including Ethernet TCP/IP and Sercos.

Bosch Rexroth's controller provides all the functionality and processing power that was

Continues On Page No.: 57



New Pouching and Cartoning Lines Get a

required for both the delta robot and the cartoning machine. The IndraMotion MLC controllers

for the poucher and cartoner are networked together using an external controller-to-controller Sercos interface, which fully integrates control of the packaging process from pouching through cartoning.

With the logic of the controller, the delta robot can track each pouch's position deterministically in real time coming off the poucher and checkweigher without requiring a vision system.

The pouching throughput speed can change and the robot will respond to the change without interruption. Networking both controllers and having the robot and the cartoner

share one control platform also made it relatively simple and more cost-effective to integrate the robot into Medifast's existing systems. Rexroth's user-friendly IndraWorks programming package was used to program the IndraMotion MLC platforms with a single uniform programming environment for logic, motion, and kinematics.

The robot is powered by Rexroth IndraDyn servo motors coupled with intelligent IndraDrive M servo drives. Both pouching and cartoning machines use Rexroth's IndraDrive Mi cabinet-free integrated servo drive/motor solution, which merges the drive electronics and servo motors into

single units that help reduce cabling requirements and the size of the control cabinet as well as the overall machine footprint. Using the IndraDrive Mi allowed KHS to eliminate a freestanding drive and control cabinet and use a smaller, machine-mounted cabinet. Removing the cabinet

and adding a delta robot let KHS align the poucher and cartoner in a straight, in-line orientation, thus streamlining the physical footprints of the

two new lines.

A human-machine interface ties in with the Rexroth IndraMotion MLC platform to control changeovers when different products are processed. Depending on the product,

the pouch can be thinner or thicker, which changes how the robot stacks the pouches.

According to Marburger, the Rexroth controller makes adjusting the robot arm's positioning a snap.

Medifast uses Overall Equipment Effectiveness (OEE) to track the performance of its manufacturing systems. Under the previous pouching/cartoning configuration the maximum

OEE they were able to achieve for a single shift was 83 percent. The specific OEE tool used by Medifast is the XL Productivity Appliance from Verne. It's described as a "bolt-on," off-the-shelf hardware/software combination that can be installed and operating in an hour and comes with a price tag of about \$4,500.

Both lines operate essentially the same way. The pouching machine is fed a paper/foil lamination supplied by Veritiv. It indexes at 70/min, but pouches are produced two up so output is in the

range of 140/min. Integrated into the KHS Bartelt system is a High Resolution Thermal Ink-Jet Printer from Mark-O-Print. A division of the Bluhm Weber Group, Mark-O-Print has been an HP partner since 2003.

Information printed on the front side of each pouch is product name, expiration date, time of day,

line identification, lot number, and a list of allergens.

Timing the Mark-O-Print printer is a Smarteye Colormark II from Tri-Tronics that looks for a registration

mark on the packaging material and signals the printer when to print. Also inspecting for red splice

tape is a Mark-Eye Pro, also from Tri-Tronics, which signals the pouching system not to dispense product into pouches that might be compromised by a splice. As a pair of pouches nears

the pickoff station and their exit from the poucher, a knife cuts them apart. Vacuum cups pick each pouch

from the mechanical grippers they're held in and places them on a pair of pedestal checkweighers from Mettler Toledo.

Here's another place where the Bosch Rexroth controls platform adds value. The robot takes inputs from

the checkweighers and only picks up and collates the good pouches, while any rejects

continue advancing

forward until they fall into a reject bin. This represents a significant improvement over the pouching/cartoning lines installed previously at Medifast, where the mechanical pouch stacking system

is designed to always place two pouches at a time into two collating buckets. That way, both collating

buckets will always have the correct complement of seven pouches each. If the checkweigher

determines that either pouch has the wrong weight, two pouches are ejected to the reject bin

even though one of them is perfectly accurate. Why? Because if the checkweigher ejected only

the bad pouch, one of the two collating buckets would be short a pouch when the collating bucket

reached the station where the stacks of seven pouches are pushed into the cartons.

With the new robotic approach, only bad pouches get rejected. Neatly collated seven-count stacks

of pouches move into the cartoner in their collating buckets and are automatically pushed into a carton.

Flaps are tucked closed and operators then case pack the cartons by hand. Assisting them is the

Combi EZ-Pack semi-automatic pack station from Combi Packaging Systems. An operator picks up

a folded corrugated case, opens it along the manufacturer joints, and places it into the bottom-folding section of the machine. Once the bottom is folded, the operator places the required

number of cartons inside and then pushes the case through the Combi system's top-and-bottom

taping section. Palletizing is done by hand.

Although this was the first time Medifast installed delta robot technology in their plant, the company's

past experience with KHS Bartelt gave everyone confidence that the move to robotic transfer

would be a success.





by:
plastemart.com

RECYCLING WITH WPC

WOOD-PLASTIC COMPOSITES (WPC'S)

WPC's are composite materials made of wood fiber / flour and plastics. In addition to wood fiber and plastic, WPC's can also contain other inorganic filler materials. WPC's can also be referred to as natural fiber plastic composites or natural fiber reinforced plastics. 100% Use of Waste Plastics (Dry & Cleaned) can be used to make WPC's.

U S E S

The most widespread use of WPC's is in outdoor deck floors, but it is also used for railings fences, landscaping timbers, cladding and siding, park benches, molding and trim, window and door frames, and indoor furniture. Manufacturers claim that wood-plastic composite is more environmentally friendly and requires less maintenance than the alternatives of solid wood treated with preservatives or solid wood of rot-resistant species. These materials can be moulded with or without simulated wood grain details.

Wood-plastic composite is still a very new material relative to the long history of natural lumber as a building material, but can be substituted in most non-structural instances. Although being highly resistant to rotting, WPC's add a stage of upstream use to materials previously considered waste lumber. WPC Lumber can be nailed, painted, varnished, cut and finished similar to wood products.

A major advantage over wood is the ability of the material to be molded to meet almost any desired spatial conditions. It can also be bent and fixed to form strong arching curves. With up to 70 percent cellulose content (although 50/50 is more common), wood-plastic composites behave like wood and can be shaped using conventional wood working tools. At the same time, they are moisture-resistant and resistant to decay, although they are not as rigid as wood and may slightly deform in extremely hot weather. A major selling point of these

materials is their lack of need for paint as they are manufactured in a variety of colours, though they are mainly available in grays and earth tones. These colours last for the lifetime of the product.

MANUFACTURING PROCESS :

Wood-plastic composite lumber is composed of wood from recovered saw dust and other cellulose-based fiber fillers such as pulp fibers, rice husk, peanut hulls, bamboo, straw, digestate, other husks, etc. and virgin or mix waste plastics including PE, PP, ABS, PS, alike. The powder or fibers are mixed to dough-like consistency and then extruded or moulded to the desired shape. Additives such as colorants, coupling agents stabilizers, blowing agents, reinforcing agents, foaming agents, lubricants help tailor the end product to the target area of application. The material is formed into both solid and hollow profiles or into injection moulded parts and products.

Wood, resin, regrind and most of the additives are combined and processed in a pelletizing extruder. The new material pellets are formed in mould and dried or extruded from a fix shaped profile die.

Plastic waste is first cleaned with a Dust Remover (Jatakia) Machine. It is then cut into small pieces using a Grinder/Agglomerator. During Grinding also, separated dust is removed from the regrind with the help of dust remover. The grinded waste is then pre-mixed in a slow/high speed mixer together with wood, husk or other fillers and other additives as required depending on end use of the profile. The mix is then put through a Force Fed, Vented Extrusion System. The melt passes through vacuum duly compressed and then extruded through the die or required shape to achieve the profile. The profile then passes through a water bath to cool faster and then cut to the required length.





**Swastik Techno
Engineers Pvt. Ltd.**
AN ISO 9001 : 2008 Certified

Delivering
Printing Solutions
Worldwide



Model : STE / 906 / 15000



Manufacturer of : Dry- offset Printing Machine.
Suitable for : PP & HIPS thermoforming
Cups and injection moulded containers

SWASTIK TECHNO ENGINEERS PVT. LTD.

Plot No. 748, New GIDC, Gundlav, Dist. VALSAD, Guj, INDIA.

Telefax:+91-2632 237213 Cell: +91-90998 13000, 98798 17339, 99135 99124

E-MAIL: swastik_valsad@yahoo.com, WEBSITE: www.swastikp-tech.com



AMBICA

ROTO TECHNOLOGIES PVT. LTD.

Create • Enhance • Sustain

An ISO 9001 : 2015 Certified Company

Manufacturer of Roto Moulding
Machines & moulds

Our product range:

- 4 Arm / 3 Arm Bi-Axial Machines
- Three / Two Station Shuttle Machines
- Single Station Bi-Axial Machines
- Open Flame Type Rock N Roll Machines
- Box Type Machine
- Pulverizer Machine for LLDPE & PVC
- Extruder Machine for Coloring & Granule Making
- Scrap Grinder
- High speed Mixer
- Rotational Moulds in SS and MS



4 Arm Bi-Axial Machine



Mirror Polished Mould



Box Machine



Rock N Roll



Extruder Machine



Single Station Bi-Axial
Machine



Pulveriser



Scrap Grinder



Mixer Machine



S.S. Mould

Add : Plot No. D-58, Diamond Park, GIDC, Naroda, Ahmedabad - 382330

Ph : +91-79-4890 3556 Mob: +91-82383 23625 / +91-99989 72778

E-mail : info@ambicarototech.com, sales@ambicarototech.com

Website: www.ambicarototech.com



Website



GLORIOUS
TOOL ROOM

Specialist :

- Carat Mould
- 2 Plate & 3 Plate Plastic Injection Moulds
- Unscrewing Moulds
- Core Pulling System Moulds
- Side Core Moving System
- Hot Runner Moulds
- Blow Moulds
- Investment Castings Dies
- Jigs & Fixtures



Carat

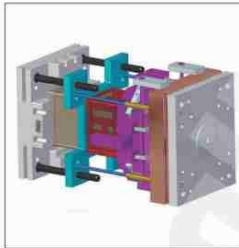

Carat Mould

**All types of Plastics
Injection moulds,
Blow Moulds,
Investment Die castings,
Jigs & fixtures
manufacturing works**



Eleptical Tub Mould



Eleptical Tub



Eleptical Tub Mould



Paint Bucket



PVC Interlock Tiles



Pail Bucket



Laundry Basket

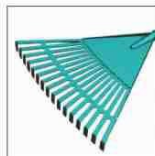

Cleaning Tools



Food Dish

GLORIOUS TOOL ROOM

Address .: 61, Nilkanth Avenubehind Hotel Plam S.P. Ring Road,
Near Kathawada Cross Road Ahmedabad

E-mail .: gallalpesh@yahoo.in, alpeshgajjar61glorious@gmail.com,
gloriestoolroom@gmail.com

Mobile .: +91-84010 51727, 90818 17315

CE

Awarded WQC
International Star Award
in the Gold Category,
Paris 2001 For Our
Commitment to Quality
in Our product.



ELECTROTECH INDUSTRIES

Corona Treatment System

FILM TREAT

Narrow Web Treater Station



High Speed Blow Film Treater Station



Multilayer / Multilayer Blow Film Treater Station



Multilayer / Multilayer Blow Film Treater Station



10.0 KW Generator Panel



Cable Treater



Narrow Web Treater Station For Label Paper



Treater Assembly For Conductive Film



Blow Film Plant Treater Station



Treater Station For High Speed Converting Lines



Treater Station For Low Speed Converting Lines



"CE Mark" Generator Panel



ELECTROTECH
INDUSTRIES

Latest IGBT Based Technology
High Speed wide Treaters For Multilayer
Film Plants/Aluminum Foilpaper etc.

Power efficiency above 90% digital display of output power
High frequency (silent) Operation 10-40-KHz
Zero Speed/Short Ckt trj with audio/visual alarm.

We also deal in Static eliminators hand held corona
Treater (US Make), Static Eliminator String (US Make).

Add.: 154, Pushkar Industrial Estate, Nr. Torrent Power Sub Station,
Opp. Macon's Factory, Phase-1, G.I.D.C., Vatva, Ahmedabad-382445. Gujarat, India

Mo.: +91-9601551913 **E-mail:** rakeshetind@gmail.com / info@etind.com **Website:** www.etind.com

SUPERMAC

Direct Clamping Hydraulic Injection Moulding Machines

SMH Series



Toggle Clamping Injection Moulding Machines

SMT Series



making moulds of innovation
in plastic applications



SUPERMAC MACHINERY

Mfg. of : PLASTIC INJECTION MOLDING MACHINES

Regd. Off. & Works : Plot No. 275, Main Road, Opp. Road No. 5

G.I.D.C. Kathwada, Ahmedabad - 382 430. (INDIA).

Phone : + 91 - 79 - 29701874, M. + 91 99980 40433

E-mail : info@supermacmachinery.com, supermacmachinery@gmail.com

www.supermacmachinery.com



TECHNOVATHERMOPLAST
Spray Nozzel



Rubber Pad



Aluminium Section



Mixer
Blades



Aluminium Casting
Heaters



Nozzles brass Heaters



Hopper Magnet



Screen
Changer



Groove Feed



Vacuum
Filter Body



Thermocouple



Cooling Cell



Spring / Screw
Conveyour



Pulveriser Machine



Online Pipe Printing
Machine



Die Head



RS Extrutech

Office : 193 Pushkar Estate, Vatva - Ramol Road, Opp. National Rifle Factory,
Phase-1, Vatva, GIDC, AHMEDABAD - 382445 (Gujarat) INDIA

Cell : +91-85112 24509, 87872 83646

E-mail : rajeshgohil79@gmail.com Web : www.rsextrutech.com

Mfrs & Exporter of Plastic Processing Machinery & Spare Parts



RS Extrutech

WE'RE SOCIAL

follow us on your
favorite social media sites.

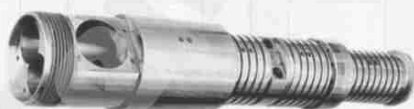

Products

- ▶ Twin Parallel Screw & Barrel
- ▶ Twin Conical Screw & Barrel
- ▶ Single Screw & Barrel
- ▶ Down Stream For Pipe Extruder
- ▶ Down Stream For Pvc Profile
- ▶ All Spares



Twin Screw Extruder



Vacuum Tank



Tractor Unit



Cutter



J.R. Corporation

IAS-ANZ



M54009131N

AS/NZS ISO 9001 2008 Certified Company



**BETTER GET
RUNNING FAST
IN COMPETITIVE AGE,
JUST WORK.**



Single Screw Extruder

J.R. Corporation Is Manufacturers Exporters & Suppliers of Plastic Scrap Grinder Machine, Plastic Extruder, Machine, Single Screw Extruder Machine, Agglomerator Machine, High Speed Mixer, Plastic Grinder Machine Spear, Color Mixer



Agglomerator



Plastic Scrap Grinder



High Speed Grinder



Plastic Scrap Grinder Machine
(Cyclone System Attachment)



Granule Color Mixer



Grinding Machine Spear Blade

Address : No. 93, Ramdev Estate, Shahwadi Bus Stop, Narol, Ahmedabad - 382405, Gujarat INDIA.

Phone : +91-79-2573 0219, Mo.: +91 98793 00942 . 99099 86822 . 99099 72552

E-mail : info@plasticextrudermachine.in . jr.corp03@gmail.com

Website : www.plasticextrudermachine.in



PELLETIZING SOLUTION

FOR RAFFIA, MULTI LAYER & ROTO MOULDING INDUSTRIES
WITH SMART FORCED FEED TECHNOLOGY **WITHOUT AGGLOMERATION.**



PELLETIZING PLANTS

Model	Output	L/D Ratio	Main Motor	Connected Load	Grinder / KW	L x W x H (Mr.)
GE-RE-75V	40-50	29	15 KW	54.5 KW	12" / 7.5	6.5 x 2.3 x 4.3
GE-RE-75HV	75-85	32	18.75 KW	58.3 KW	15" / 11.25	6.7 x 2.5 x 4.3
GE-RE-90V	100-110	32	22.5 KW	63.35 KW	18" / 18.75	7.3 x 2.5 x 4.3
GE-RE-100V	130-150	32	37.5 KW	98.4 KW	18" / 22.5	7.7 x 2.6 x 4.3
GE-RE-120V	160-200	29	45 KW	111.5 KW	21" / 30	7.9 x 2.7 x 4.3
GE-RE-120HV	250-300	32	56.25 KW	137.5 KW	21" / 30	8.2 x 2.7 x 4.3

Silent Features :-

- Suitable for light, Semi dense & dense Material.
- **SMART FORCE FEEDER TECHNOLOGY** helps to process ground film, Raffia tape directly **WITHOUT AGGLOMERATION.**
- Removal of Agglomeration process leads to pelletizing of waste with minimum degradation of materials.
- Lower shear rate compared to other machines which helps to retain its physical & chemical properties.
- Minimum Power consumption with maximum output approx 0.3 units / kg. hr.
- Machine is able to perform at 85% efficiency of its rated output for minimum 12000 Hours without any major maintenance under standard condition.
- Special designed watering die face Cutter & De-Watering Unit.
- Higher productivity with consistent granule size.
- Suitable for LDPE, LLDPE, HDPE, HM, PP, PP NON WOVEN, BOPP, ABS, PC, PS, EVA in form of film, Yarns, Fabric & Article Waste.



GAURAV ENGINEERING

Works (H.O.) : Plot No. 152, Road No. 5, Kathwada GIDC, Nr. Barcelona Circle, Ahmedabad, Gujarat, India.

Cell : +91 98256 15621, +91 98251 35621,

Vapi Office : Plot No. 223/1, 2nd Phase, Nr. Moraraji Circle, GIDC, Vapi, Gujarat, India.

Cell : +91 94290 28751



E-mail : gauravenggvapi@gmail.com / gauravengg@rediffmail.com, Web : www.gauravengg.com

For purity you can see through.



Self-Cleaning
Continuous Type
Screen Changers

Applications:

- Tape Plant • Woven Sack Plant • Pipe Plant • Film Plant
- Sheet Plant • Non-woven Fabric Plant

Advantages:

- It filters the plastic material and removes impurities, thereby preventing damage to the die & barrel and hence increases the life of the machine
- Quality of the final product remains consistently good
- Leakage problem gets eliminated
- Absolutely eliminates the idle time
- Maximum utilization of plant becomes possible

- Increases the life of candle mesh due to flushing operation and hence saves money
- Easy to operate
- Eliminates material wastage
- Saves energy due to non-stop working of line
- Candle clubbed wire mesh can be changed without stopping the extruder line and this increases the production

Installation support:

Complete installation work will be carried out by providing Barrel Side and Die Side Flange Adapters, followed by a trial.

Rajhans

Manufacturer of all types of Screen Changers, Melt Pump System & Breaker Plate Cleaner

RAJHANS PLASTIC MACHINERY PVT. LTD.

An ISO 9001:2008 Certified Company

Plot No. 5777-B, Jagtashion Mill Compound, Nr. Kiran Industries, Phase-1, GIDC, Vatva, Ahmedabad-382445, Gujarat, India.

Ph.: +91-79-2563 0003, 2589 5852, 2589 5853 Fax: +91-79-2589 1838

E-mail: exports@rajhansindia.com Visit us at: www.rajhansindia.com

Because consistency is the biggest benchmark of quality.



Why you should go for our Melt Pump Systems?

- More accurate gauge control
- Elimination of extruder gauge variation
- Significant material savings
- Higher product quality
- Increase in profits with reduced scrap & enhanced life of extruder
- Increases the output of the plant
- Faster start ups
- Fast pay backs due to linear & non-stop production
- Easy to operate

We also provide the following Screen Changers & Breaker Plate Cleaners

- Plunger Type Manual
- Self Cleaning Continuous Type
- Platen Type
- Normal Continuous Type
- Cassette Type Continuous
- Double Plunger Continuous Type
- Lever Type
- Breaker Plate Cleaner



Manufacturer of all types of Screen Changers,
Melt Pump Systems & Breaker Plate Cleaners

RAJHANS PLASTIC MACHINERY PVT. LTD.

An ISO 9001:2008 Certified Company

Plot No. 57/7-8, Jagfashion Mill Compound, Nr. Kiran Industries, Phase-1, GIDC, Vatva, Ahmedabad-382445, Gujarat, India.

Ph.: +91-79-2583 0003, 2589 5852, 2589 5853 Fax: +91-79-2589 1838

E-mail: exports@rajhansindia.com Visit us at: www.rajhansindia.com

SHREEJITECH ENGINEERING

Our Products

- Slitter Rewinder Machine
- Doctoring Rewinding Machine
- Web Guiding System
- Rotogravure Printing Machine
- Alluminium Foil Rewinder Machine
- Bopp Tape Cutting Machine
- Bopp Coating Plant
- Core Cutter Machine
- PVC Tape Cutting Machine
- Stretch Wrapping Machine
- Masking Tape Machine



High Speed Rotogravure Printing Machine



Bopp Tape Cutting Machine (Automatic)



Core LODER (Automatic)



Paper Core Cutting Machine (semi Automatic)



Bopp Tape Cutting Machine



MINI Bopp Tape Cutting Machine



MINI Rewinder Machine



Paper Core Cutting Machine (Pedal Type)

We Also Provide Converting Machinery Equipments



Masking Tape Slicer (Automatic) Machine

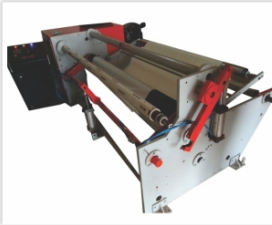

Masking Tape Rewinder Machine



PVC TAPE Slicer Machine (Automatic)



Drum Type Paper Slitter Rewinder Machine



High Speed Paper Slitter Rewinder Machine



Paper Core Cutting Machine (Manual)



Rotogravure Printing Machine

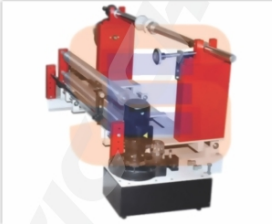

Unwinder Unit

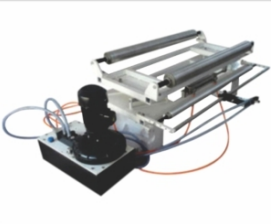

Web Aligner Unit With Trally

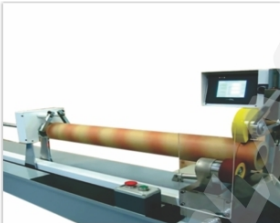

Fully Automartic Paper Core Cutting Machine



BOPP Coating Machine



PVC Slicer Machine (Manual)



Address : Office : 120, Pushkar Estate Opp. Macons,
Phase 1, Vatva GIDC, Ahmedabad-382445 Gujarat, India

Contact No : +91-7940092311, +91-9033441485, 8758409090

Email : sales_shreejitecheng@hotmail.com, shreejitecheng@hotmail.com

Web : www.shreejitechengineering.com

eLPie®

Choose to Craftspeople

Calender-eLP

PP/PS SHEET LINE

Form-eLP

EPS THERMOFORMING MACHINE

Leadership Through Innovation, Quality and Service

OUR PRODUCT RANGE INCLUDES

- PP/PS Sheet Extruder Line
- R PET Sheet Line
- Thermoforming Machine for PP/PS Disposables
- EPS Foam Sheet Line
- Thermoforming Machine for EPS Disposables
- Extrusion Coating for EPS Foam Sheet
- Monolayer Blown Film Line
- Multilayer Blown Film Line
- PPTQ Blown Film Line

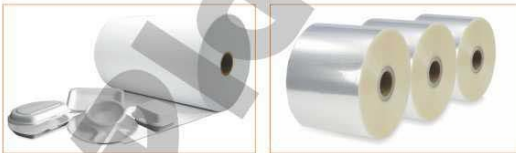

HALL 3, STALL F06

HALL STALL

ELPIE ENGINEERS PVT. LTD.

Plot No. 2, Survey No. 13/2/P1, NH-27, Nr. Bharudi Toll Plaza, Pipadiya (Village),
Taluka: Gondal, Dist: Rajkot-360 311, Gujarat, INDIA
Mobile : +91 97129 73716 Email : jjaghera@elpie.in, Web : www.elpie.in